

Bevel Back Weatherboard System

PRODUCT
SPECIFICATION
DOCUMENT

SUGI

Contents

Japanese Cedar Weatherboard System	1
Standard Profile Range	3
Standard Flashings	5
Exterior Oil Colour Range	6
Yakisugi (Charred) Finishes	7
Wabi Sabi Colour Range	8
Yakisugi Oil Application and Maintenance	9
Installation Guide	13
Handling & Storage	39
Producer's Statement	40
Warranty	41
Ioka Exterior Oil Safety Data Sheet	43
Dryden Oil Stain Product Data Sheet	50
Dryden Oil Stain Safety Data Sheet	60
SCION Durability Document	67
BEAL Appraisal Certificate	68

Japanese Cedar Weatherboard System

Overview

Grown in the cold climate and fertile soils of Japan, our authentic Japanese cedar is a world class, sustainably harvested, durable timber ideal for exterior cladding. The geographical location of the forests produce a highly desirable grain structure with warmth and lustre that readily accepts oils and stains.

SPECIES	Japanese cedar (Cryptomeria Japonica)
ORIGIN	Japan
SUSTAINABILITY	World class planting and management systems in place. GOHO certification.
CHEMICAL TREATMENTS	None
DURABILITY	Naturally durable with no additional harmful chemicals or treatments. Minimum 15 year service life as per NZBC
DENSITY	320-384kg/cm ³ (@ 12% M.C)
QUALITY CHARACTERISTICS	All SUGI timber is carefully graded into specific categories, each grade offers a unique aesthetic and level of natural defect appealing to different types of architecture. Sound tight knots and naturally occurring defects are permissible and adhere to NZS 3602
VISUAL AESTHETIC	Prominent growth rings, variable colour and feature defects
TIMBER COLOUR	Warm reddish brown and light red hues and dark streaking
RADIAL SHRINKAGE	1.3% (green to 12% M.C)

TANGENTIAL SHRINKAGE	3.5% (green to 12% M.C)
GRADES	Premium clears and select appearance (knotty)
DRYING	Air dried 15-20% M.C. at time of dispatch
MACHINE COATING	Dryden 2 coat system ready for installation with no on site coating required other than cut ends
LENGTHS	4000mm , 2000mm standard lengths (other lengths available on request)
WIDTHS	50mm, 75mm, 100mm and 150mm
THICKNESSES AVAILABLE (RS)	20mm
FINISHES	Dressed, Band sawn, Wire brushed face
FIXINGS	Stainless steel cladding screw, silica bronze cladding screw, or rose head annular groove nail

Standard Profile Range

A full range of architectural profile drawings available on request.

VERTICAL SHIPLAP WEATHERBOARD

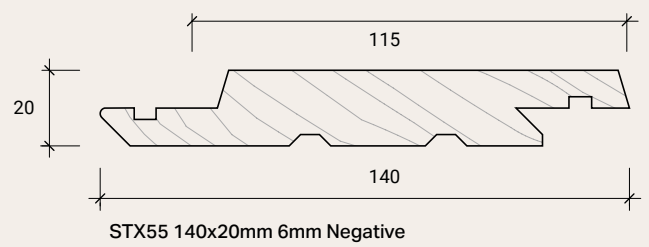
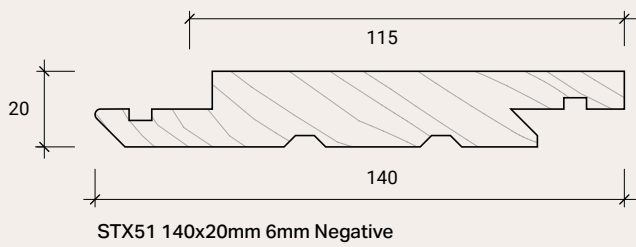

HORIZONTAL BEVEL BACK WEATHERBOARD

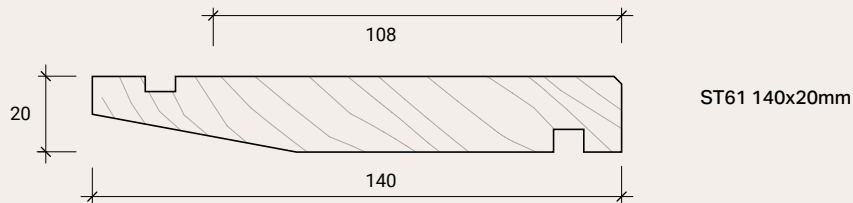

RUSTICATED HORIZONTAL SHIPLAP WEATHERBOARD

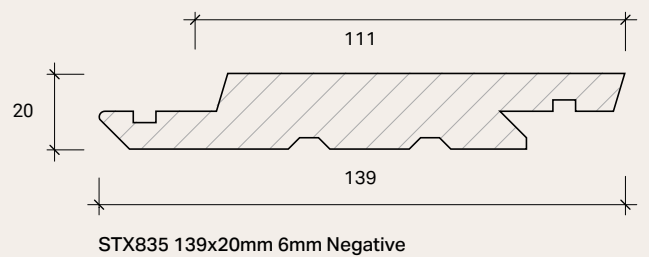
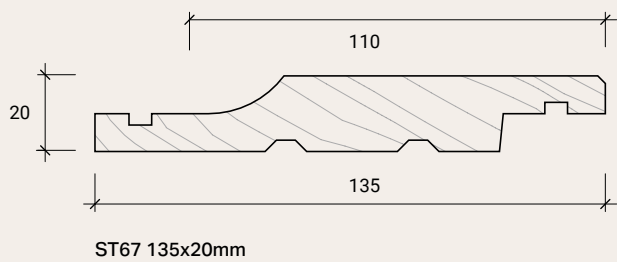

BOARD AND BATTEN WEATHERBOARD

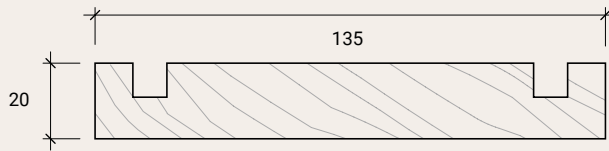

ST120 135x20mm

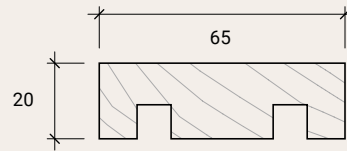

ST123 65x20mm

FASCIA

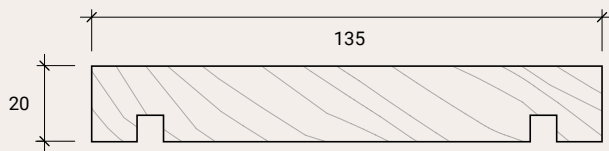

ST69 135x20mm

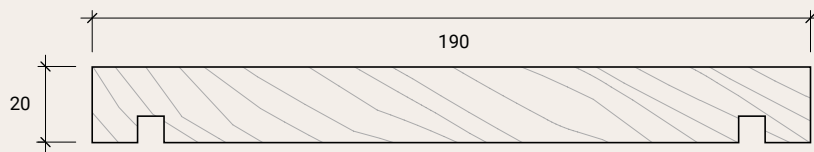

ST70 190x20mm

D4S MOULDINGS AND FACINGS

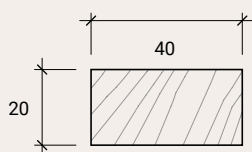

ST101 40x20mm

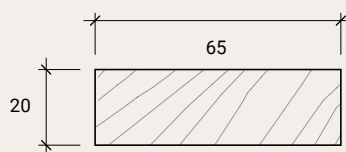

ST102 65x20mm

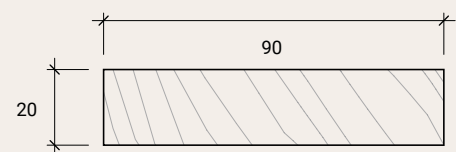

ST103 90x20mm

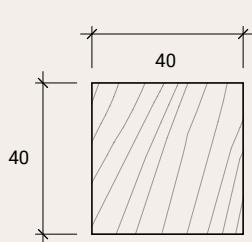

ST110 40x40mm

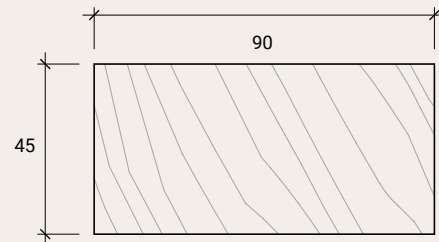

ST109 90x45mm

FLASHINGS

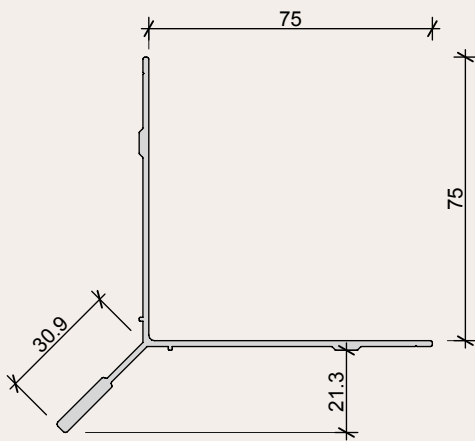

VTFL- 41 Mitred external corner flashing 19mm

Extrusion Length: 5.85m
 Mill finish or powder-coated black
 Periphery 368mm (area for PC)

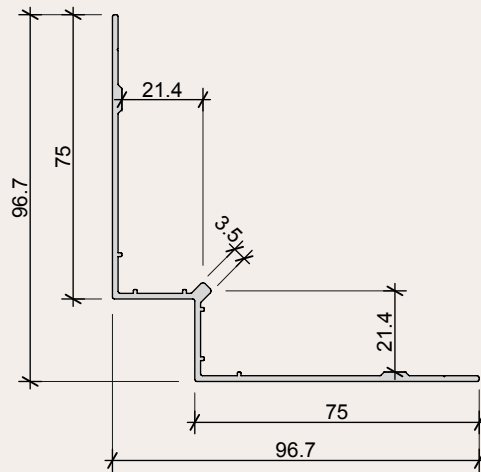

VTFL - 39 Internal corner flashing 19mm

Extrusion Length: 5.85m
 Mill finish or powder-coated black
 Periphery 404mm (area for PC)

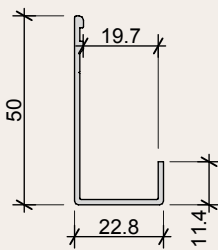

VTFL- 11 J-mould flashing 19mm

Extrusion Length: 5.85m
 Mill finish or powder-coated black
 Periphery 169mm (area for PC)

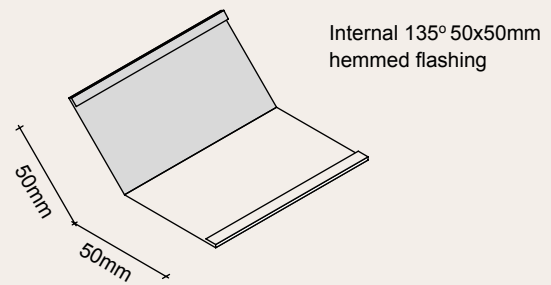

Internal 135° 50x50mm
 hemmed flashing

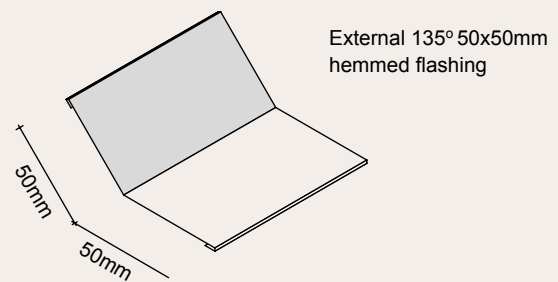

External 135° 50x50mm
 hemmed flashing

Dryden Exterior Oil Colour Range



Clear



Moetapu



Walnut



Slate



Driftwood



Dune



Teak



Platinum

Yakisugi (Charred) Finishes



Dento

Charred + Oiled

Japanese cedar heat treated and charred then coated with natural oil. The thick layer of carbon gives the timber longevity, UV and weather protection, as well as fire resistance. Natural oil solidifies the carbon layer prolonging the finish by preventing fine layers of soot from coming off.

Traditionally a maintenance optional finish, we recommend re-oiling every 10-20 years to prolong the layer of black carbon.



Makkuro

Charred + Brushed + Oiled

Japanese cedar heat treated and charred then lightly brushed before being factory coated using natural oil to protect and prolong the natural colour of the timber.

The light brush leaves behind a smooth, lightly burned appearance that gains character with age. In Japan, the patina that develops over the years is valued for its beauty. Oil-coating every 5-10 years is recommended.



Wabi Sabi

Charred + Heavy Brush + Oiled

Available in a range of oil colours.

Japanese cedar heat treated and charred then brushed twice removing most of the char from the softwood and leaving carbon only on the fine hardwood grain.

Once the softwood is exposed it readily accepts natural colour oils before we do a final factory coat to seal.

Wabi Sabi Dryden Oil Colours



Clear



Moetapu



Walnut



Slate



Driftwood



Dune



Platinum

YAKISUGI DENTO

IOKA Char Oil Application and Maintenance Guidelines

Overview

IOKA Char Oil is a penetrating, non-filming, natural plant chemistry timber protector made in New Zealand. Designed for charred timber cladding, IOKA Char Oil is suitable for application on all exterior wood, decks, outdoor furniture and can also be specified for interior finishing.

Surface Finish – Charred + Oiled

Our Yakisugi DENTO is the traditional surface finish seen across Japan for centuries. This dragon like skin has a hygroscopic surface which manages water ingress and egress as part of its natural science. DENTO requires all cut ends to be coated with IOKA Char Oil prior to installation.

Application

All DENTO Yakisugi products have been factory coated all sides with 2 x coats of IOKA Char Oil.

During installation DENTO requires 1 x coat of IOKA Char Oil to be applied to all cut ends of timber where raw timber is exposed. An additional amount of the IOKA Char Oil will be supplied to do this on site. Oil can be applied with either a speed brush, lambs wool brush head applicator, 6mm foam roller or quality paint brush.

IMPORTANT NOTE - It is important to apply an even thin coat of product to the face as thick coats of product will result in "clouding" due to oxygen being trapped under the surface of the oil. This cannot be remediated and must be avoided.

Maintenance

DENTO is a maintenance optional product. If maintained on a 24-48 month cycle DENTO will remain in as / new condition and continue to exhibit the dragon like texture. If no maintenance is carried out the charred surface will gradually change and evolve over time. Fading, pock marks and lugs (charred pieces) will become loose and fall off exposing the warm brown thermally modified surface underneath. This uneven weathered patina is

celebrated across Japan expressing completely unique appearances to each and every different building due to differing styles of architecture, orientation and exposure to UV. Over a very long period of time the charred surface will have completely evacuated with the entire face back to the raw thermally modified timber which eventually will finalise the process in a beautiful silver patina.

IMPORTANT NOTE - It is important to note that although the range of Yakisugi products from SUGi will require significantly less maintenance than traditional timbers, one must consider the surrounding factors that will play a part in the speed of natural deterioration (weathering). Environmental conditions, building design, orientation and geographical location can dramatically reduce the time frame between maintenance intervals.

Cleaning of Implements

Immediately after use clean equipment with white spirits or mineral turps, followed by soap and water. (for best results use a plant based detergent)

Safety Instructions

Do not pour oil residue into the sewer. Let the remnants dry out and dispose with your domestic rubbish collection. Do not crumple soaked rags (otherwise spontaneous combustion may occur)

Ingredients

Tung Nut Oil, Isoparafin L, Gum Rosin, Carnauba Wax, Candelilla Wax, Eucalyptus Oil, Lead free Driers, Acticide.

YAKISUGI MAKKURO

Dryden Exterior Oilstain Application Guidelines

Overview

Dryden exterior oilstain is a deeply penetrating oil that nourishes timber from within. It has water resistant properties that helps prevent the absorption of water into timbers, reducing excessive warping, cupping, and splitting of timber, thus extending the life span of those timbers. It does not film on the surface, and therefore will not crack, flake or peel. Suitable for application on cladding, decking, hardwood outdoor furniture and other exterior timbers.

Surface Finish – Charred + Brushed + Oiled

Makkuro is a once brushed charred product machine coated with two coats of Dryden oilstain 'midnight' applied. The brushing removes the charred dragon skin outer layer and results in a light expression of the latewood bands being prominent as the softer material in the earlywood has been removed in the thermal modification process of charring. Makkuro comes with the added strength of having a thermally modified outer layer of timber, creating a more tactile surface for high traffic areas where the charred surface coming off on contact is possible.

Application

All MAKKURO Yakisugi products have been machine coated with two coats of Dryden oilstain " midnight " applied.

During installation MAKKURO requires one coat of DRYDEN oilstain 'midnight' to be applied to all cut ends of timber where raw timber is exposed. Oil can be applied with either a speed brush, lambs wool brush head applicator, 6mm foam roller or quality paint brush.

IMPORTANT NOTE – All excess oil on the show face must be either removed with a rag or spread out with a speed brush or paint brush to avoid gloss patching. It is important to apply an even thin coat of product to the face as thick coats of product will result in product building up and setting like a gloss finish due to the resin component in the oil that sets during the oxidation process. This cannot be remediated and must be avoided.

YAKISUGI WABI SABI

Dryden Exterior Oilstain Application Guidelines

Overview

Dryden exterior oilstain is a deeply penetrating oil that nourishes timber from within. It has water resistant properties that helps prevent the absorption of water into timbers, reducing excessive warping, cupping, and splitting of timber, thus extending the life span of those timbers. It does not film on the surface, and therefore will not crack, flake or peel. Suitable for application on cladding, decking, hardwood outdoor furniture and other exterior timbers.

Wabi Sabi Surface Finish – Charred + Heavy Brush + Colour Oiled

WABI SABI is our charred, twice brushed and then coloured product. This vigorous process will remove the outer dragon like skin as well as a lot of the thermally modified outer layer of the timber pronouncing the late wood bands that exhibit the darker colour due to thermal modification (charring). WABI SABI must go through this process of removing carbon to take on coloured oils.

Application

All WABI SABI Yakisugi products have been machine coated with two coats of Dryden oilstain applied.

During installation WABI SABI requires one coat of DRYDEN oilstain 'midnight' to be applied to all cut ends of timber where raw timber is exposed. Oil can be applied with either a speed brush, lambs wool brush head applicator, 6mm foam roller or quality paint brush.

IMPORTANT NOTE – All excess oil on the show face must be either removed with a rag or spread out with a speed brush or paint brush to avoid gloss patching. It is important to apply an even thin coat of product to the face as thick coats of product will result in product building up and setting like a gloss finish due to the resin component in the oil that sets during the oxidation process. This cannot be remediated and must be avoided.

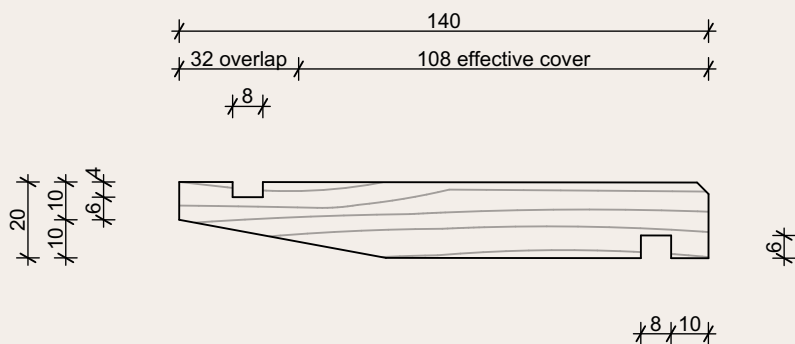

**SUGi Japanese Cedar ST61 140x20mm
Bevel Back Weatherboard**

NOTES

- All nail fixings pre-drilled min. 1mm diameter smaller than nail gauge.
- All Sugi NZ Ltd timber products to be pre-coated and cut ends and edges and all fresh cut surfaces double coated and sealed before fixing. All timbers are to be coated as per Dryden's specification.
- All corner flashings to be 75 x 75mm to suit all wind zones. All flashings to have hemmed edges to NZBC E2/AS1.
- Avoid contact in seaspray zones or corrosion zone D between CCA treated timber and metal flashings. Refer NZBC E2/AS1 Table 21

	DRAWING Bevel Back Weatherboard System Weatherboard Profiles	SCALE 1:2 @ A4	ISSUE DATE 19-03-2026	13
--	---	-------------------	--------------------------	-----------

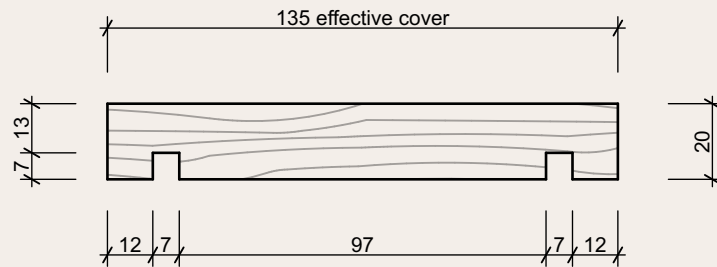

Sugi Japanese Cedar ST69 135x20mm Fascia

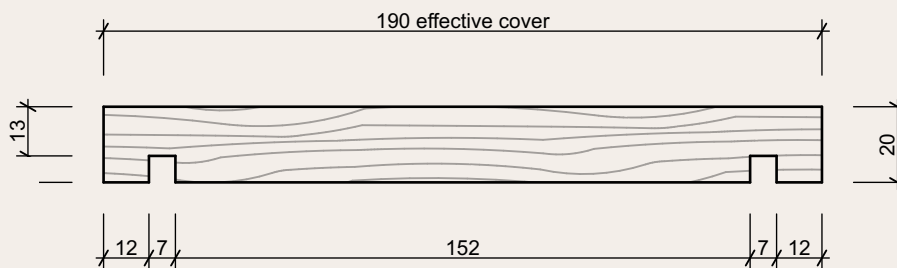

Sugi Japanese Cedar ST70 190x20mm Fascia

NOTES

- All nail fixings pre-drilled min. 1mm diameter smaller than nail gauge.
- All Sugi NZ Ltd timber products to be pre-coated and cut ends and edges and all fresh cut surfaces double coated and sealed before fixing. All timbers are to be coated as per Dryden's specification.
- All corner flashings to be 75 x 75mm to suit all wind zones. All flashings to have hemmed edges to NZBC E2/AS1.
- Avoid contact in seaspray zones or corrosion zone D between CCA treated timber and metal flashings. Refer NZBC E2/AS1 Table 21

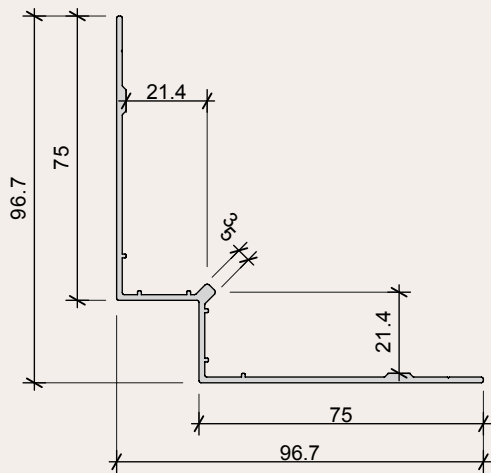

STFL - 39 Internal corner flashing 19mm

Extrusion Length: 5.85m
 Mill finish or powder-coated black
 Periphery 404mm (area for PC)

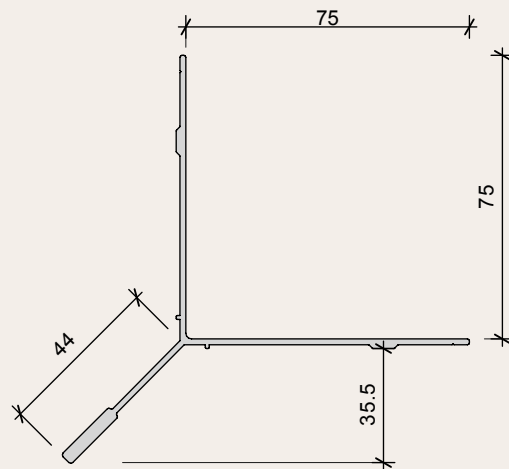

STFL- 42 Mitred external corner flashing

Extrusion Length: 5.85m
 Mill finish or powder-coated black Periphery
 368mm (area for PC)

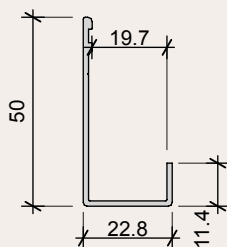

STFL- 11 J-mould flashing 19mm

Extrusion Length: 5.85m
 Mill finish or powder-coated black
 Periphery 169mm (area for PC)

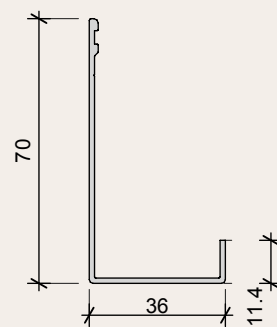

STFL- 15 J-mould flashing 36mm

Extrusion Length: 5.85m
 Mill finish or powder-coated black
 Periphery 169mm (area for PC)

NOTES

- All nail fixings pre-drilled min. 1mm diameter smaller than nail gauge.
- All Sugi NZ Ltd timber products to be pre-coated and cut ends and edges and all fresh cut surfaces double coated and sealed before fixing. All timbers are to be coated as per Dryden's specification.
- All corner flashings to be 75 x 75mm to suit all wind zones. All flashings to have hemmed edges to NZBC E2/AS1.
- Avoid contact in seaspray zones or corrosion zone D between CCA treated timber and metal flashings. Refer NZBC E2/AS1 Table 21

	DRAWING Bevel Back Weatherboard System Flashings	SCALE 1:2 @ A4	ISSUE DATE 19-03-2026	15
--	--	----------------	-----------------------	-----------

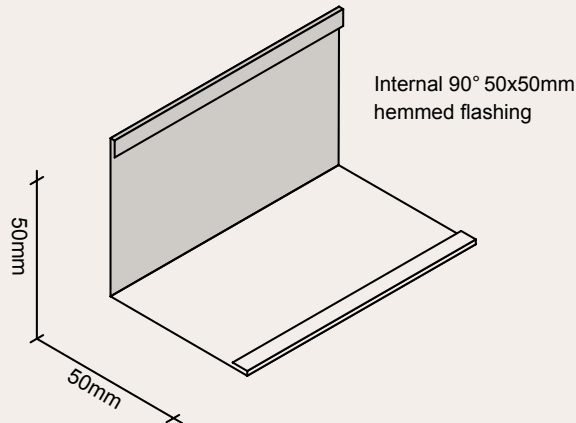
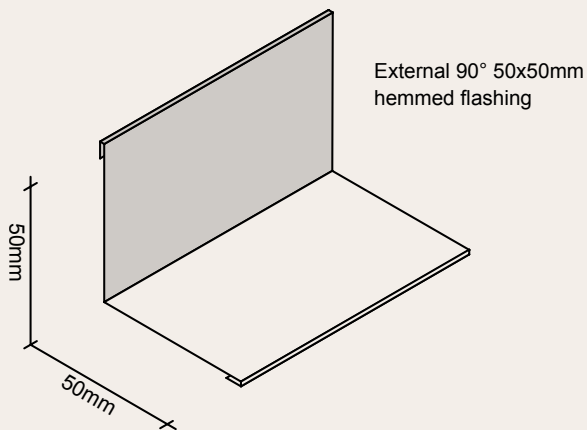
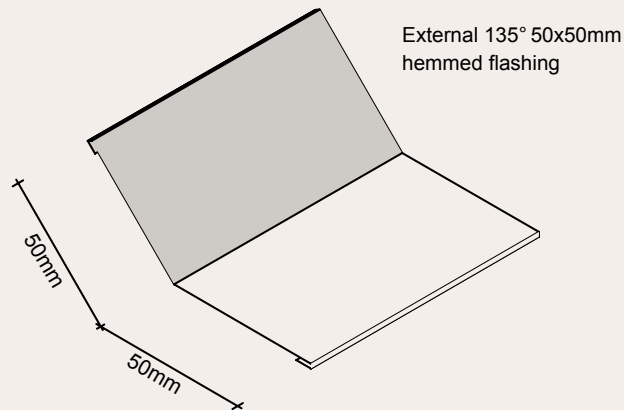
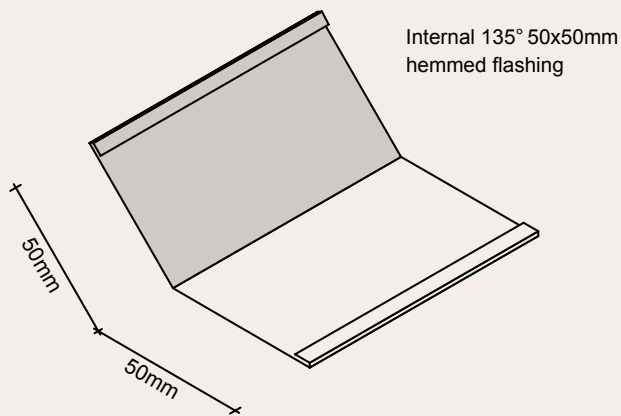

NOTES

- All nail fixings pre-drilled min. 1mm diameter smaller than nail gauge.
- All Sugi NZ Ltd timber products to be pre-coated and cut ends and edges and all fresh cut surfaces double coated and sealed before fixing. All timbers are to be coated as per Dryden's specification.
- All corner flashings to be 75 x 75mm to suit all wind zones. All flashings to have hemmed edges to NZBC E2/AS1.
- Avoid contact in seaspray zones or corrosion zone D between CCA treated timber and metal flashings. Refer NZBC E2/AS1 Table 21

	<p>DRAWING Bevel Back Weatherboard System Flashings</p>	<p>SCALE 1:2 @ A4</p>	<p>ISSUE DATE 19-03-2026</p>	<p>16</p>
---	--	-----------------------	------------------------------	------------------

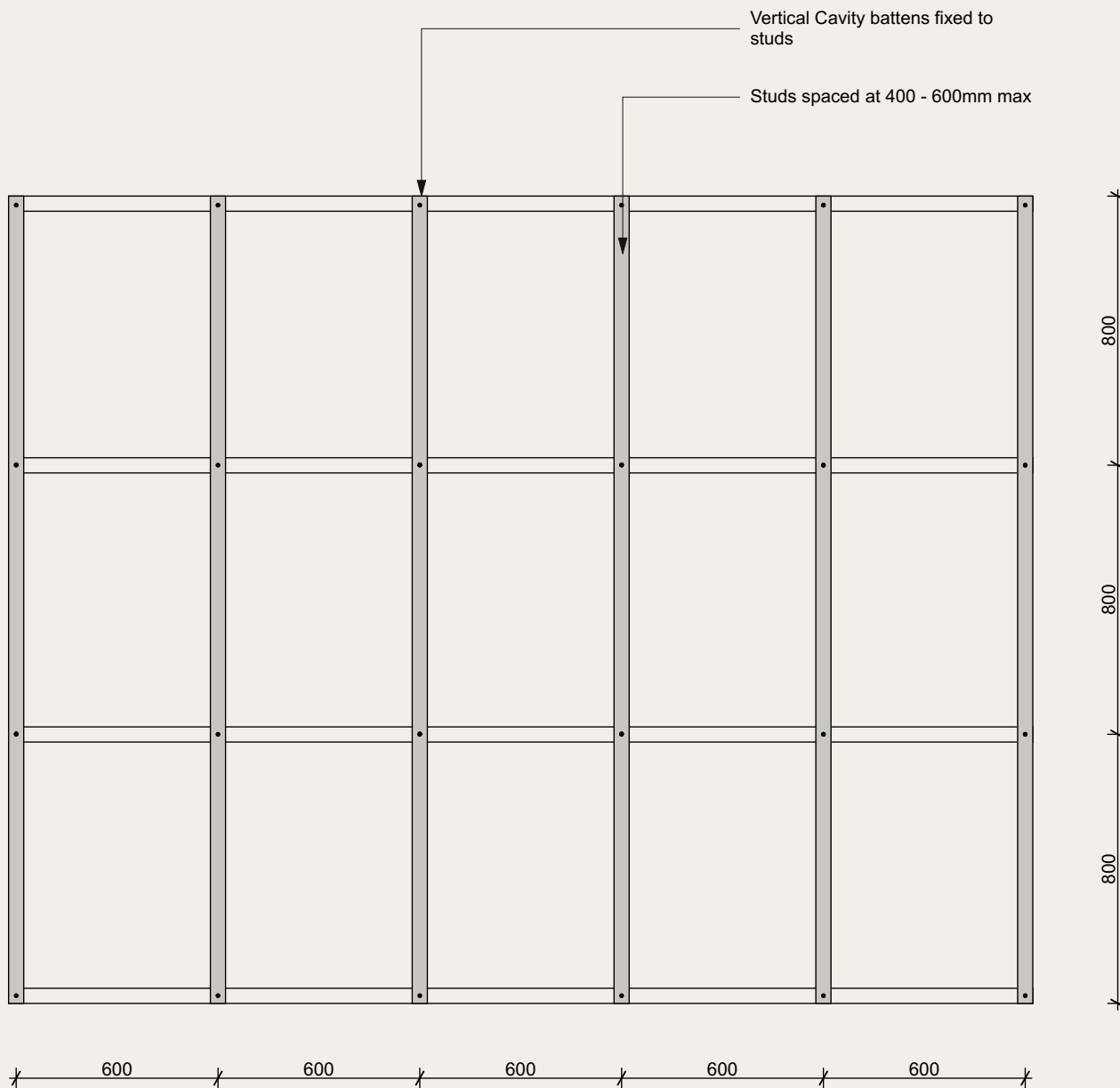

NOTES

- All nail fixings pre-drilled min. 1mm diameter smaller than nail gauge.
- All Sugi NZ Ltd timber products to be pre-coated and cut ends and edges and all fresh cut surfaces double coated and sealed before fixing. All timbers are to be coated as per Dryden's specification.
- All corner flashings to be 75 x 75mm to suit all wind zones. All flashings to have hemmed edges to NZBC E2/AS1.
- Avoid contact in seaspray zones or corrosion zone D between CCA treated timber and metal flashings. Refer NZBC E2/AS1 Table 21

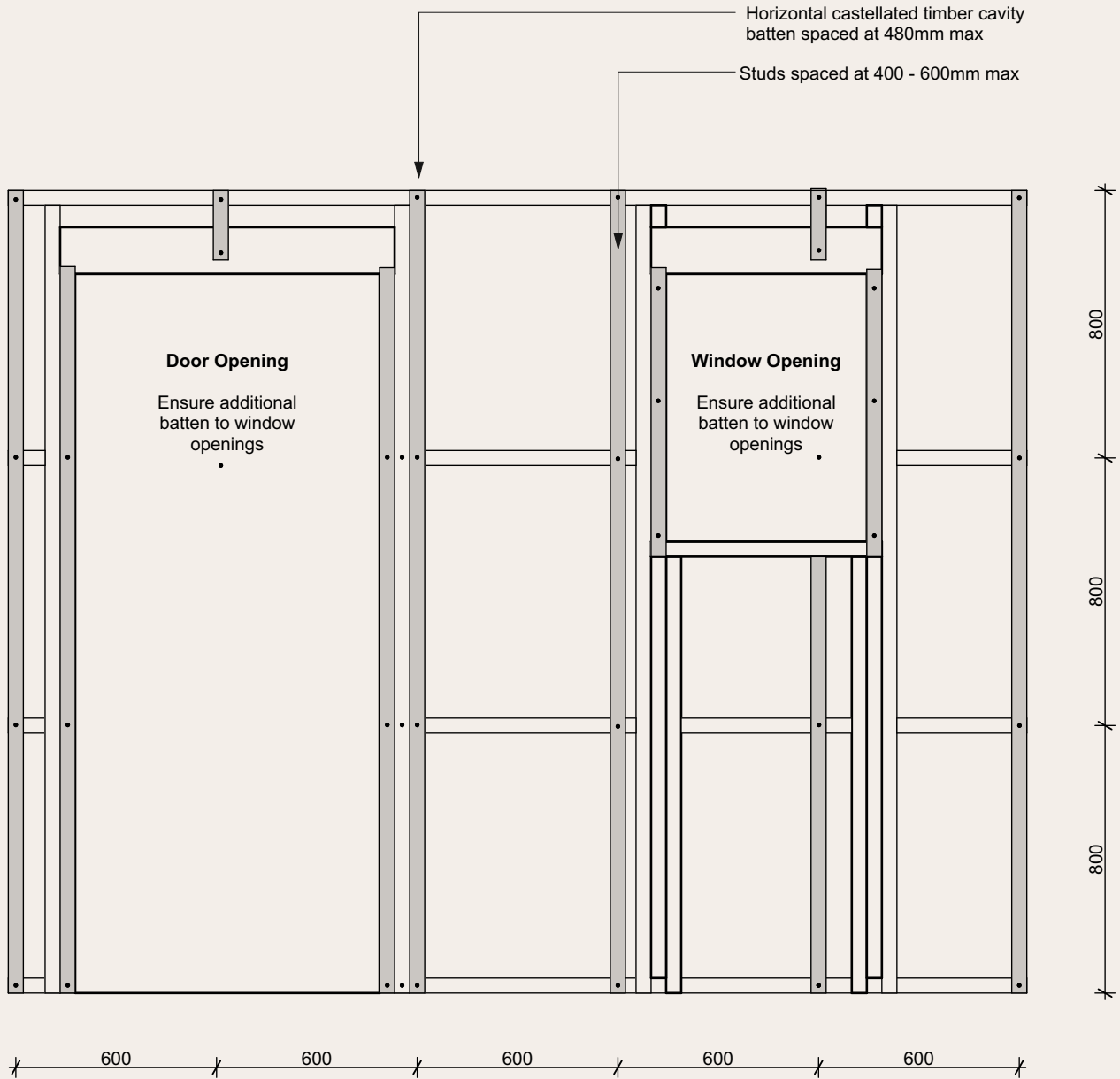

NOTES

- All nail fixings pre-drilled min. 1mm diameter smaller than nail gauge.
- All Sugi NZ Ltd timber products to be pre-coated and cut ends and edges and all fresh cut surfaces double coated and sealed before fixing. All timbers are to be coated as per Dryden's specification.
- All corner flashings to be 75 x 75mm to suit all wind zones. All flashings to have hemmed edges to NZBC E2/AS1.
- Avoid contact in seaspray zones or corrosion zone D between CCA treated timber and metal flashings. Refer NZBC E2/AS1 Table 21

	<p>DRAWING</p>	<p>Bevel Back Weatherboard System Cavity Batten Layout (W&D)</p>	<p>SCALE 1:2 @ A4</p>	<p>ISSUE DATE 19-03-2026</p>	<p>18</p>
---	----------------	---	---------------------------	----------------------------------	------------------

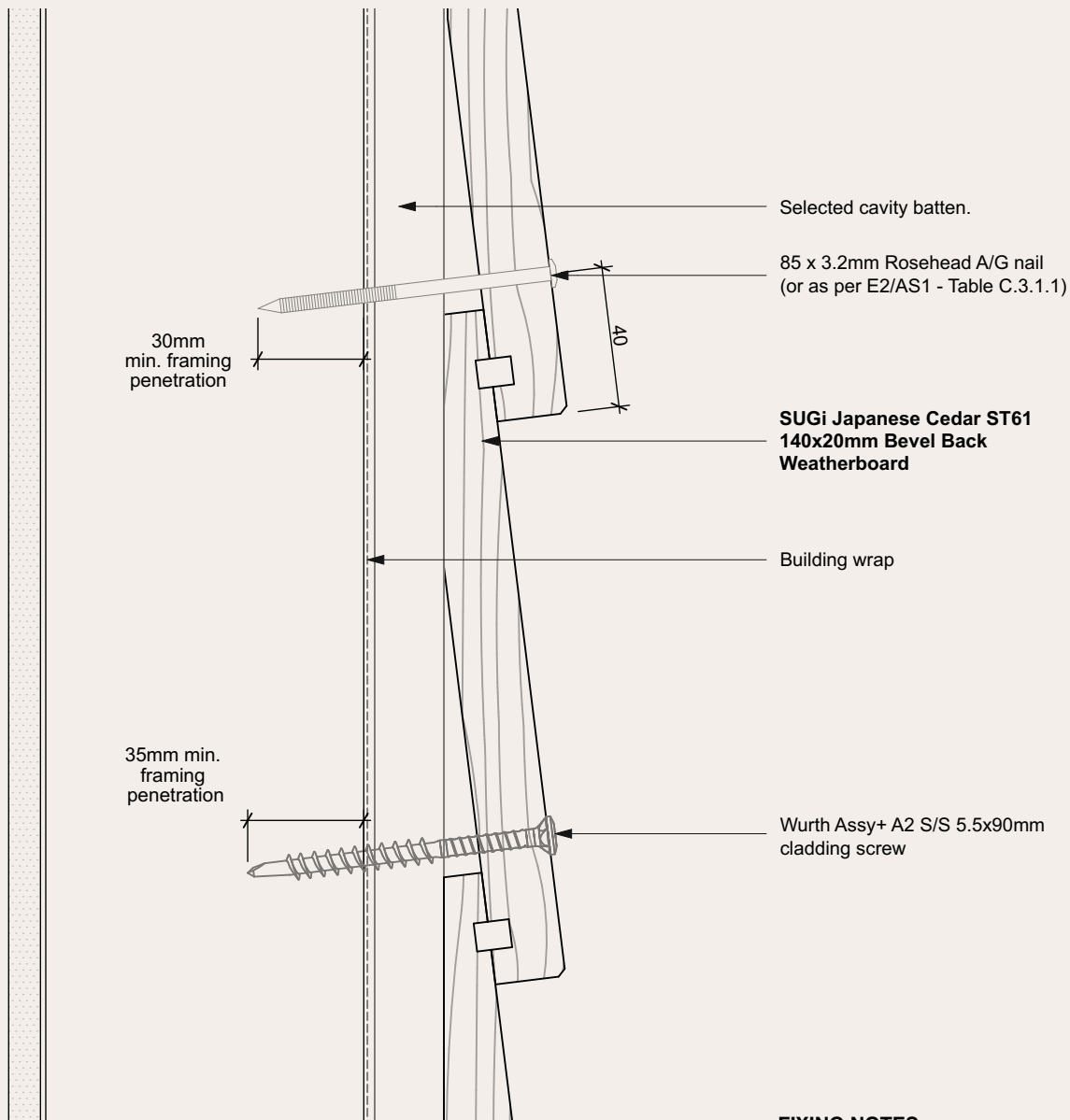

FIXING NOTES

Stainless Steel Fixings

- Rosehead A/G 100 x 4.0mm
- Rosehead A/G 75 x 3.15mm
- Rosehead A/G 60 x 3.15mm
- Rosehead A/G 38 x 3.15mm

Silicone Bronze Fixings

- Rosehead A/G 100 x 4.0mm
- Rosehead A/G 75 x 3.15mm
- Rosehead A/G 60 x 3.15mm
- Rosehead A/G 38 x 3.15mm

Stainless Steel Screws

- WURTH ASSY® plus A2 S/S 5.5x90mm

NOTES

- All nail fixings pre-drilled min. 1mm diameter smaller than nail gauge.
- All Sugi NZ Ltd timber products to be pre-coated and cut ends and edges and all fresh cut surfaces double coated and sealed before fixing. All timbers are to be coated as per Dryden's specification.
- All corner flashings to be 75 x 75mm to suit all wind zones. All flashings to have hemmed edges to NZBC E2/AS1.
- Avoid contact in seaspray zones or corrosion zone D between CCA treated timber and metal flashings. Refer NZBC E2/AS1 Table 21

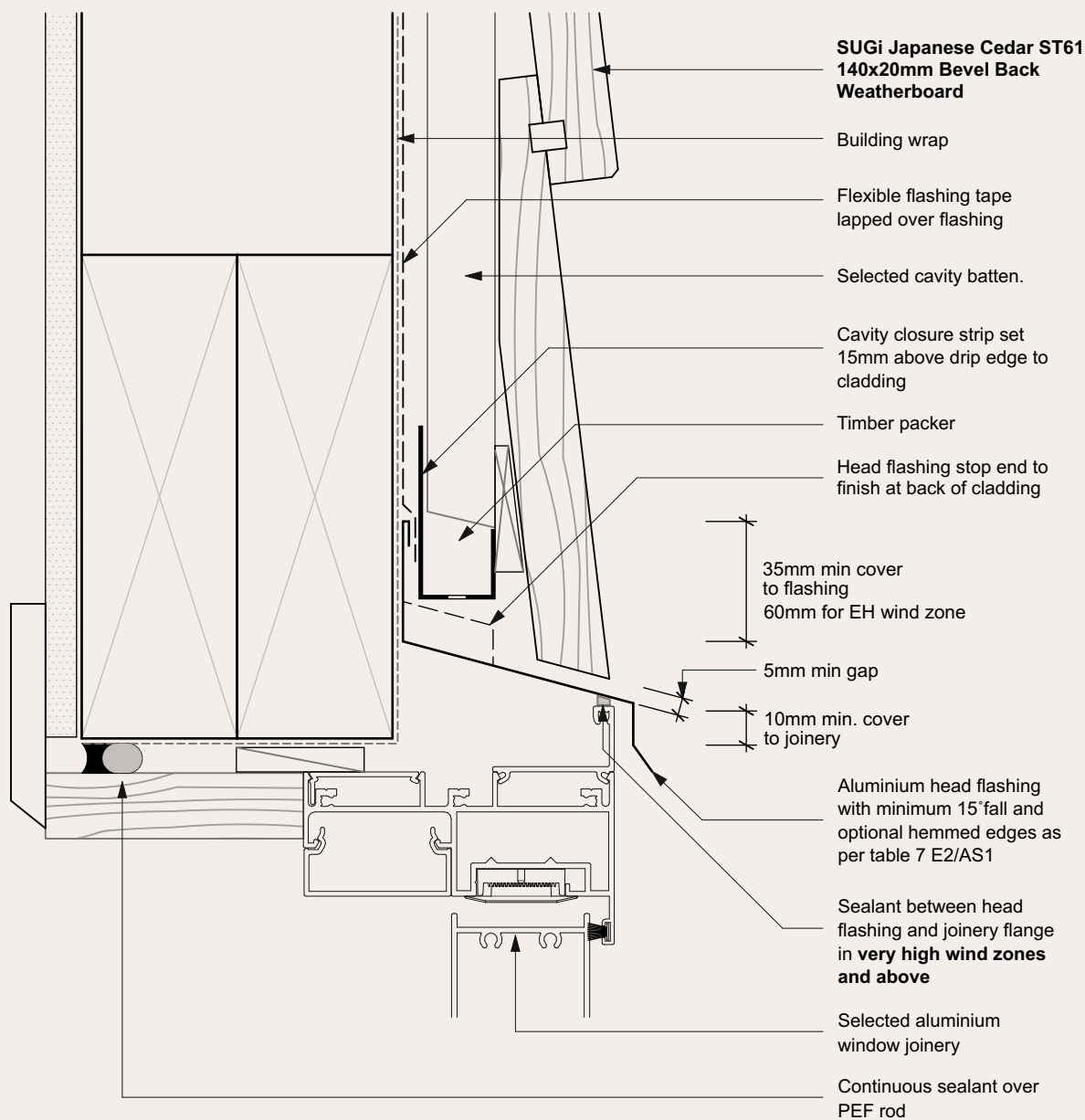

NOTES

- All nail fixings pre-drilled min. 1mm diameter smaller than nail gauge.
- All Sugi NZ Ltd timber products to be pre-coated and cut ends and edges and all fresh cut surfaces double coated and sealed before fixing. All timbers are to be coated as per Dryden's specification.
- All corner flashings to be 75 x 75mm to suit all wind zones. All flashings to have hemmed edges to NZBC E2/AS1.
- Avoid contact in seaspray zones or corrosion zone D between CCA treated timber and metal flashings. Refer NZBC E2/AS1 Table 21

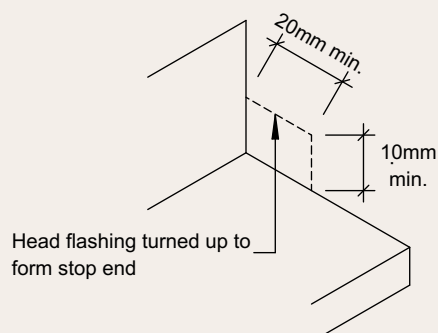

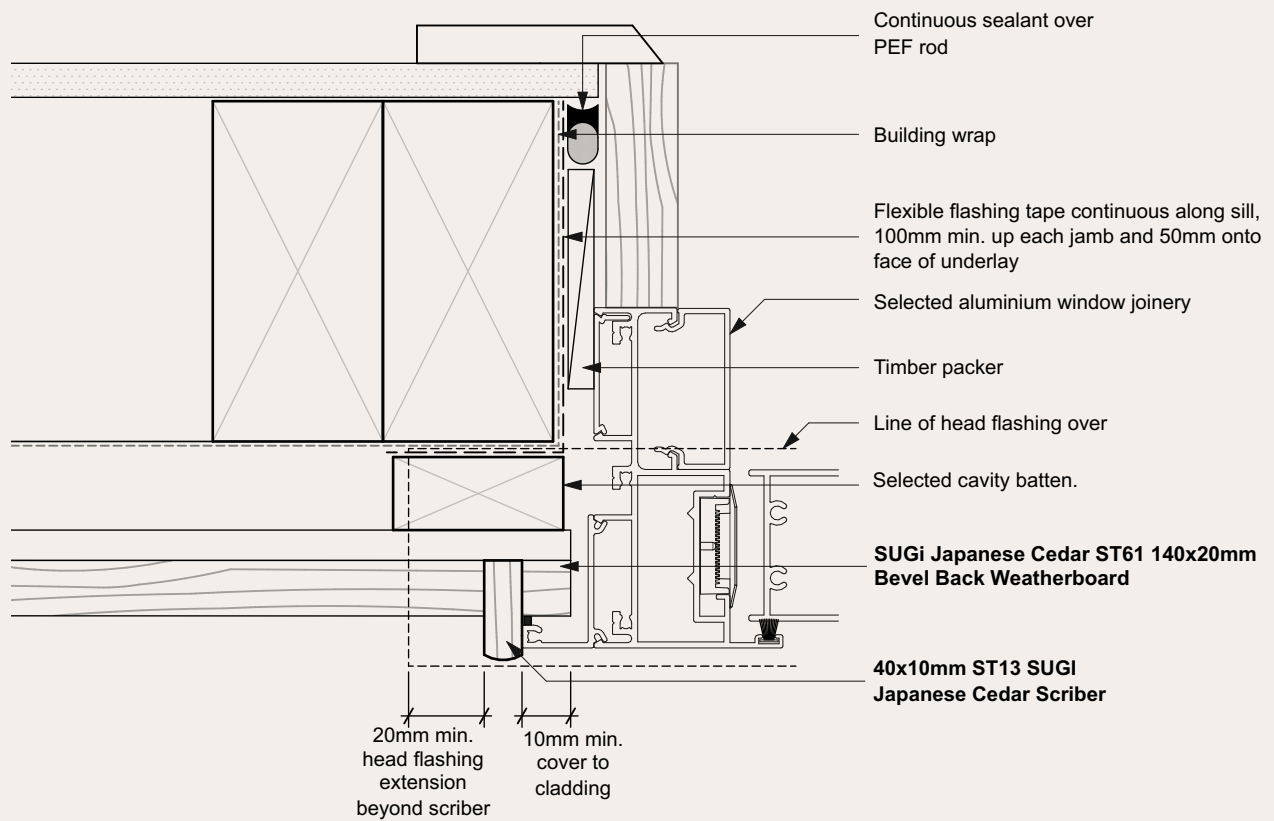

NOTES

- All nail fixings pre-drilled min. 1mm diameter smaller than nail gauge.
- All Sugi NZ Ltd timber products to be pre-coated and cut ends and edges and all fresh cut surfaces double coated and sealed before fixing. All timbers are to be coated as per Dryden's specification.
- All corner flashings to be 75 x 75mm to suit all wind zones. All flashings to have hemmed edges to NZBC E2/AS1.
- Avoid contact in seaspray zones or corrosion zone D between CCA treated timber and metal flashings. Refer NZBC E2/AS1 Table 21

	<p>DRAWING Bevel Back Weatherboard System Window Jamb Detail</p>	<p>SCALE 1:2 @ A4</p>	<p>ISSUE DATE 19-03-2026</p>	<p>21</p>
--	---	---------------------------	----------------------------------	------------------

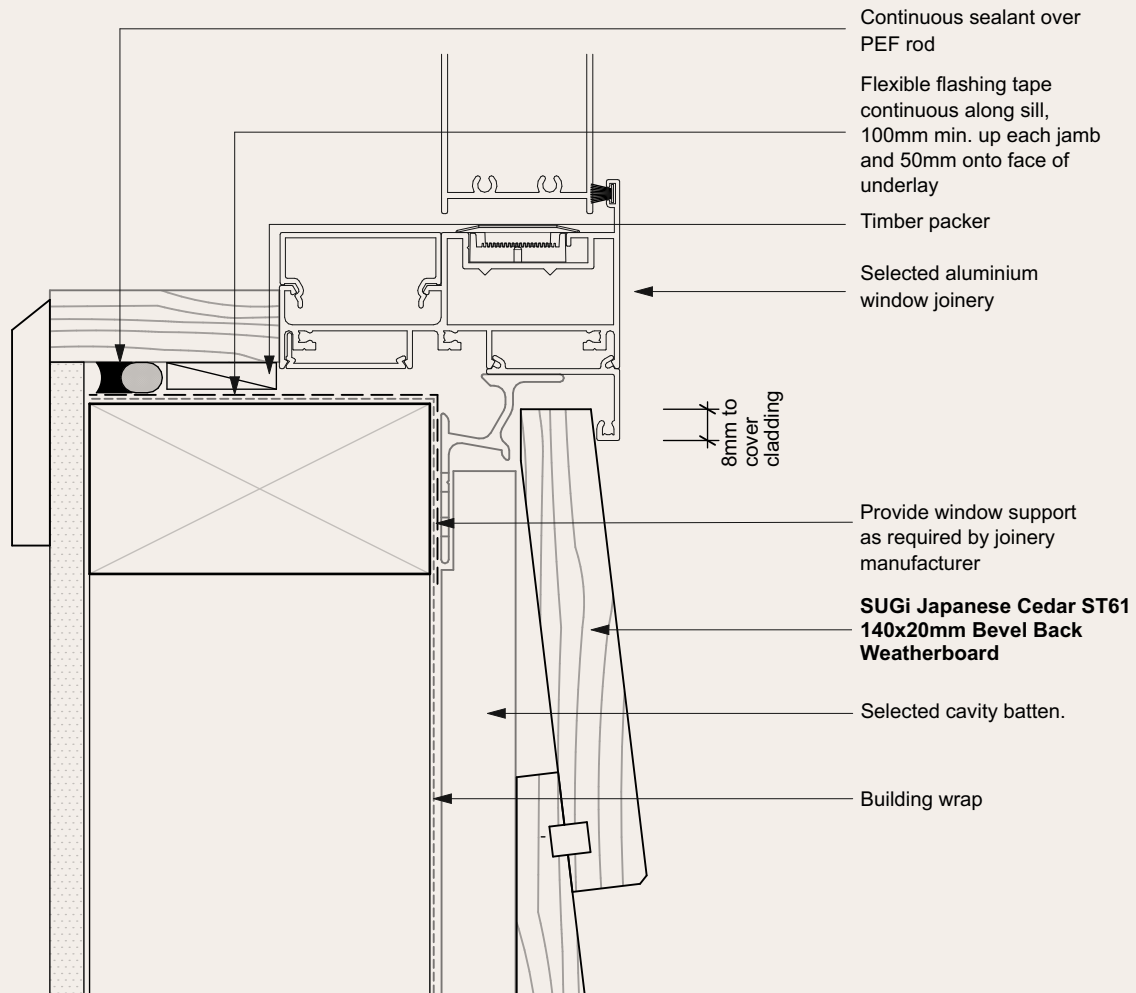

NOTES

- All nail fixings pre-drilled min. 1mm diameter smaller than nail gauge.
- All Sugi NZ Ltd timber products to be pre-coated and cut ends and edges and all fresh cut surfaces double coated and sealed before fixing. All timbers are to be coated as per Dryden's specification.
- All corner flashings to be 75 x 75mm to suit all wind zones. All flashings to have hemmed edges to NZBC E2/AS1.
- Avoid contact in seaspray zones or corrosion zone D between CCA treated timber and metal flashings. Refer NZBC E2/AS1 Table 21

	<p>DRAWING Bevel Back Weatherboard System Window Sill Detail</p>	<p>SCALE 1:2 @ A4</p>	<p>ISSUE DATE 19-03-2026</p>	<p>22</p>
---	---	-----------------------	------------------------------	------------------

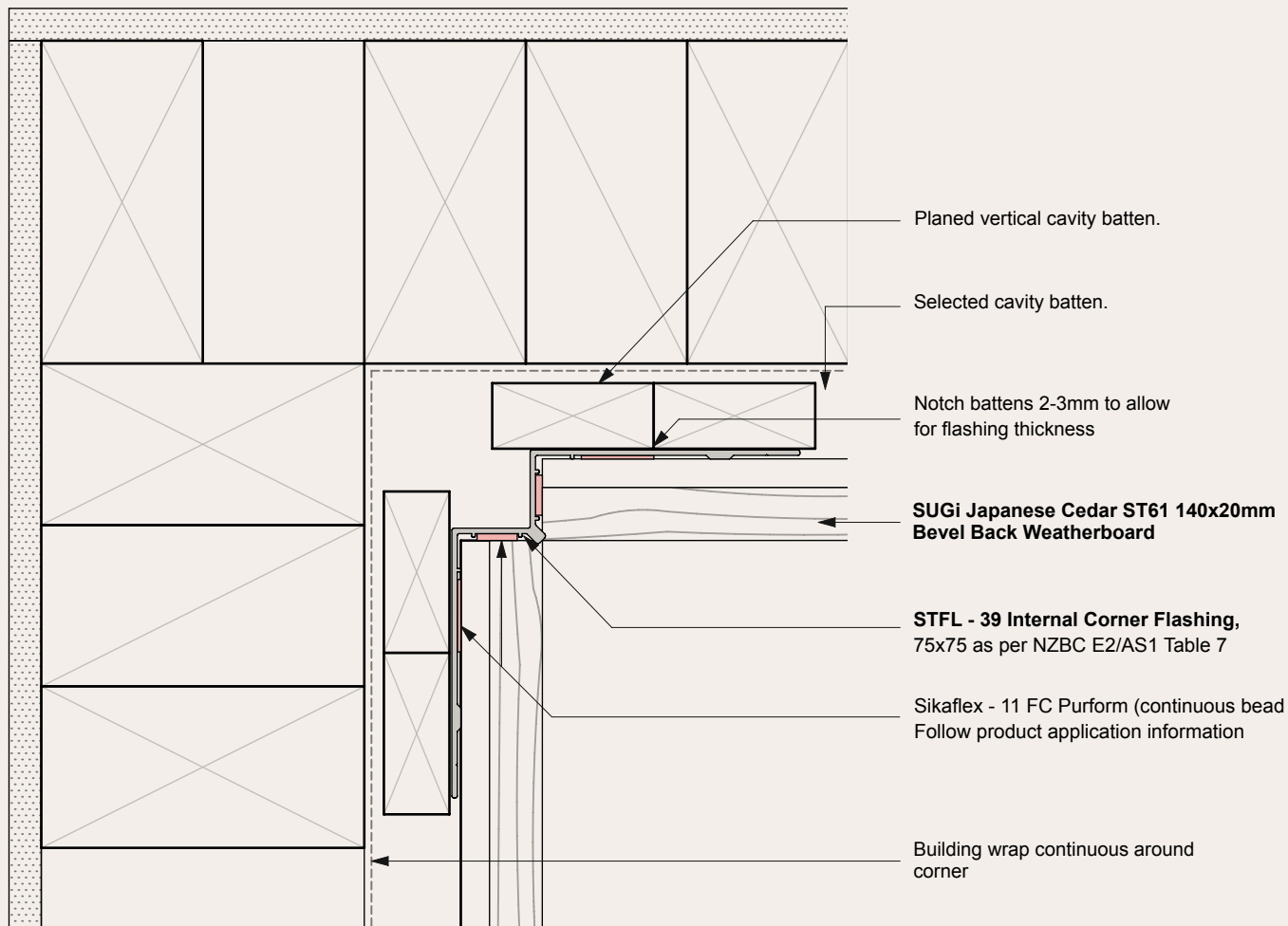

NOTES

- All nail fixings pre-drilled min. 1mm diameter smaller than nail gauge.
- All Sugi NZ Ltd timber products to be pre-coated and cut ends and edges and all fresh cut surfaces double coated and sealed before fixing. All timbers are to be coated as per Dryden's specification.
- All corner flashings to be 75 x 75mm to suit all wind zones. All flashings to have hemmed edges to NZBC E2/AS1.
- Avoid contact in seaspray zones or corrosion zone D between CCA treated timber and metal flashings. Refer NZBC E2/AS1 Table 21

	<p>DRAWING Bevel Back Weatherboard System Internal Corner Detail</p>	<p>SCALE 1:2 @ A4</p>	<p>ISSUE DATE 19-03-2026</p>	<p>23</p>
--	---	---------------------------	----------------------------------	------------------

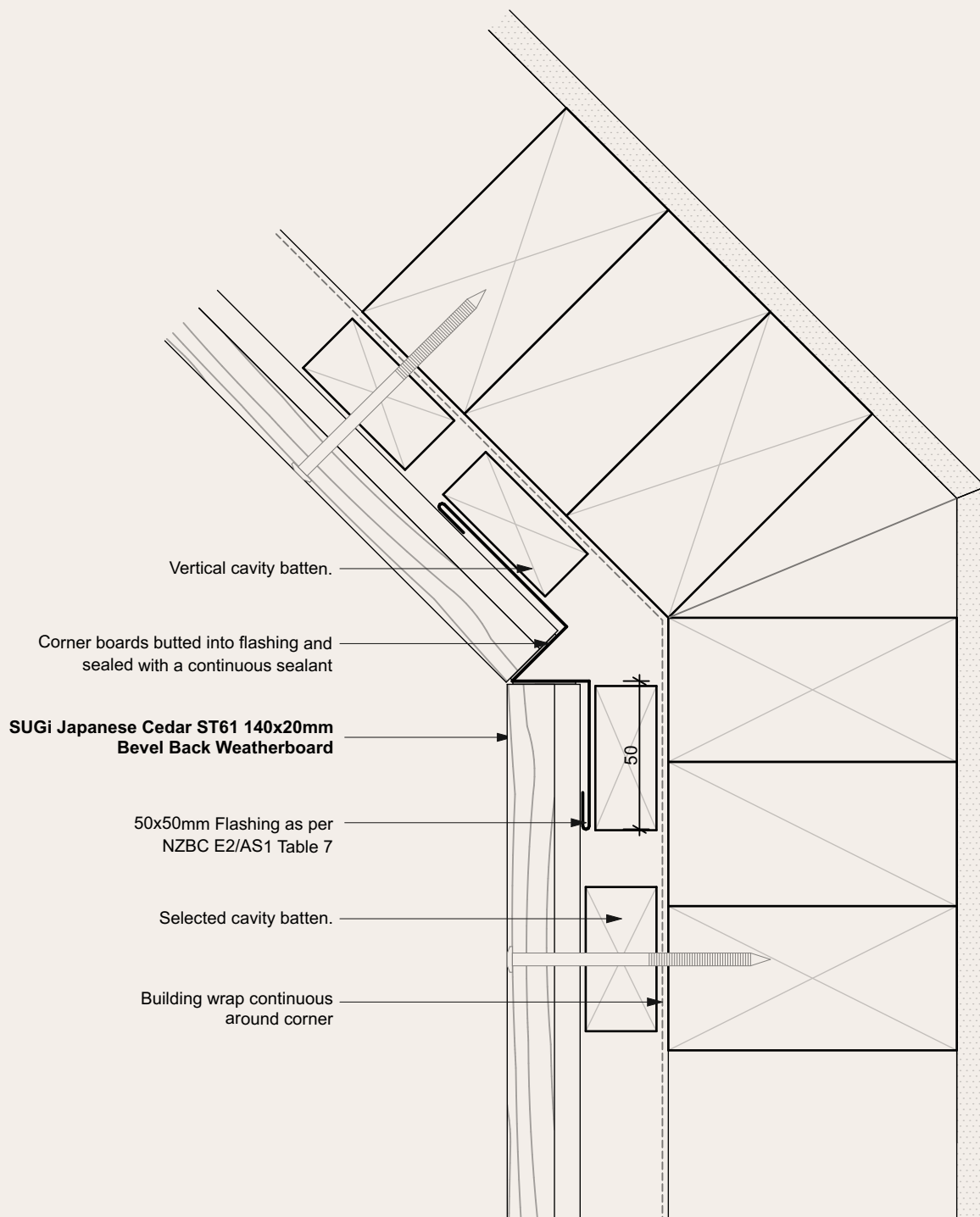

NOTES

- All nail fixings pre-drilled min. 1mm diameter smaller than nail gauge.
- All Sugi NZ Ltd timber products to be pre-coated and cut ends and edges and all fresh cut surfaces double coated and sealed before fixing. All timbers are to be coated as per Dryden's specification.
- All corner flashings to be 75 x 75mm to suit all wind zones. All flashings to have hemmed edges to NZBC E2/AS1.
- Avoid contact in seaspray zones or corrosion zone D between CCA treated timber and metal flashings. Refer NZBC E2/AS1 Table 21

	<p>DRAWING</p>	<p>Bevel Back Weatherboard System 135 Degree Internal Corner Detail</p>	<p>SCALE 1:2 @ A4</p>	<p>ISSUE DATE 19-03-2026</p>	<p>24</p>
--	----------------	---	------------------------------------	---	------------------

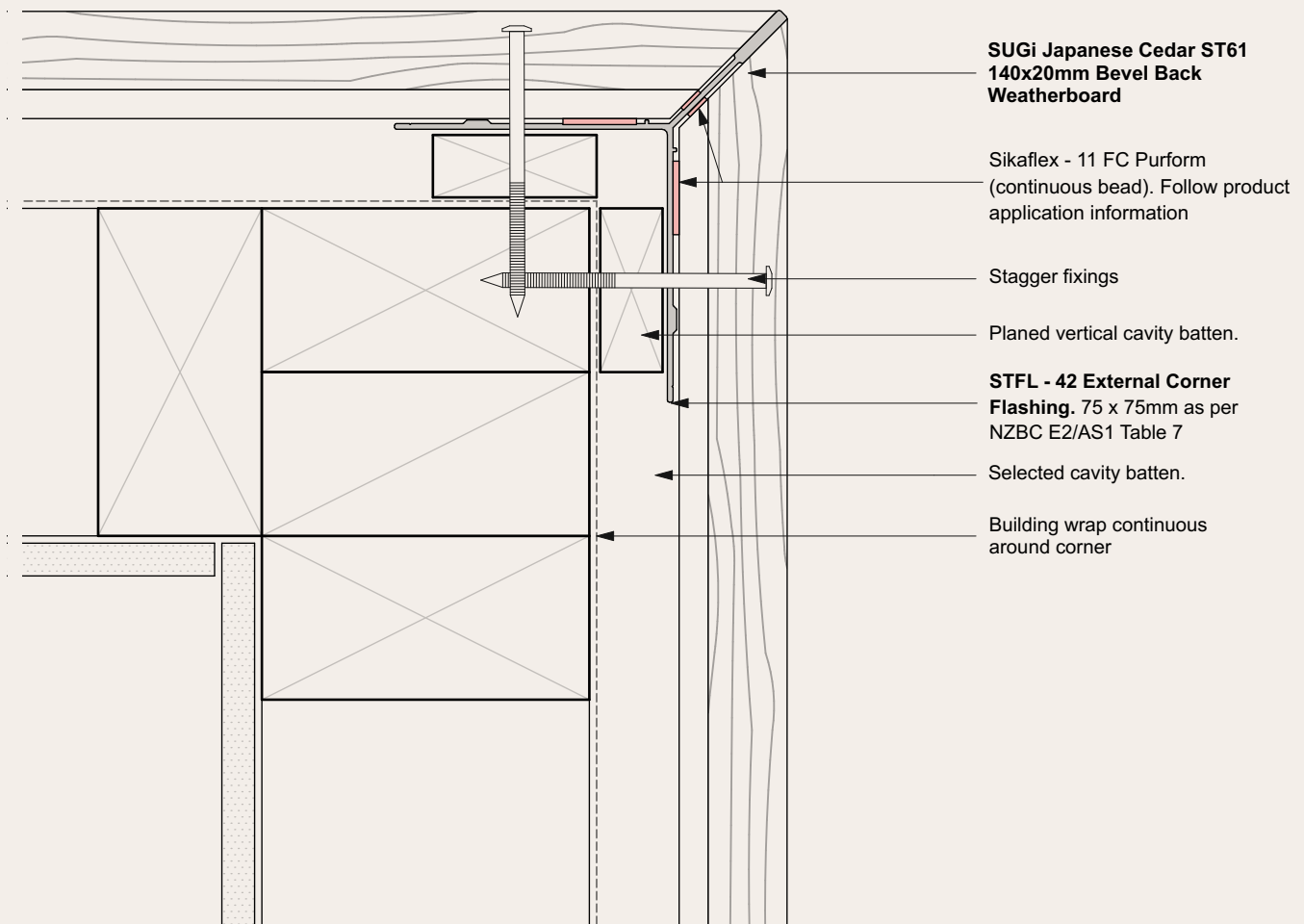

NOTES

- All nail fixings pre-drilled min. 1mm diameter smaller than nail gauge.
- All Sugi NZ Ltd timber products to be pre-coated and cut ends and edges and all fresh cut surfaces double coated and sealed before fixing. All timbers are to be coated as per Dryden's specification.
- All corner flashings to be 75 x 75mm to suit all wind zones. All flashings to have hemmed edges to NZBC E2/AS1.
- Avoid contact in seaspray zones or corrosion zone D between CCA treated timber and metal flashings. Refer NZBC E2/AS1 Table 21

	<p>DRAWING Bevel Back Weatherboard System External Corner Detail</p>	<p>SCALE 1:2 @ A4</p>	<p>ISSUE DATE 19-03-2026</p>	<p>25</p>
---	---	---------------------------	----------------------------------	------------------

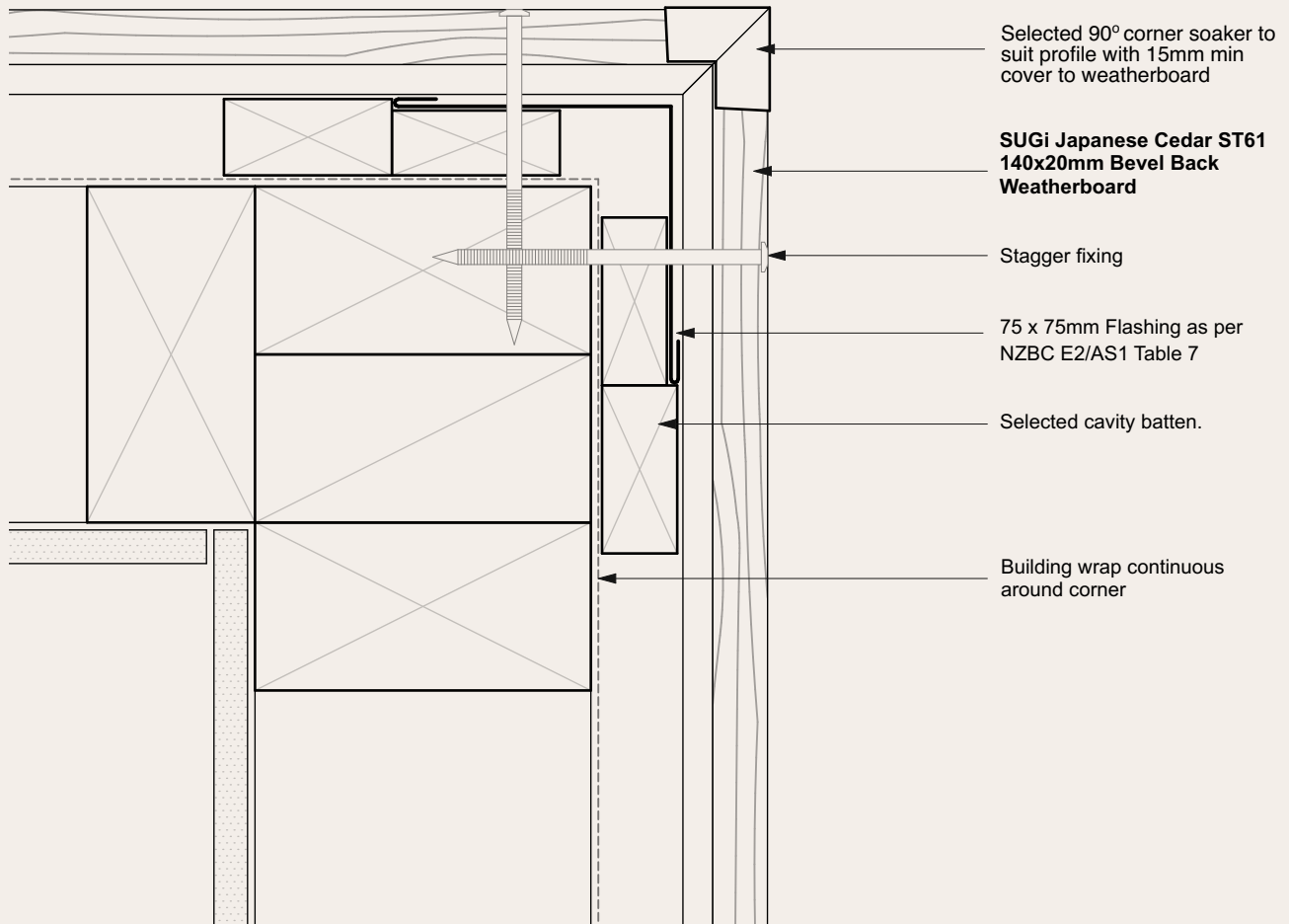

NOTES

- All nail fixings pre-drilled min. 1mm diameter smaller than nail gauge.
- All Sugi NZ Ltd timber products to be pre-coated and cut ends and edges and all fresh cut surfaces double coated and sealed before fixing. All timbers are to be coated as per Dryden's specification.
- All corner flashings to be 75 x 75mm to suit all wind zones. All flashings to have hemmed edges to NZBC E2/AS1.
- Avoid contact in seaspray zones or corrosion zone D between CCA treated timber and metal flashings. Refer NZBC E2/AS1 Table 21

	<p>DRAWING Bevel Back Weatherboard System External Corner Detail</p>	<p>SCALE 1:2 @ A4</p>	<p>ISSUE DATE 19-03-2026</p>	<p>26</p>
---	---	---------------------------	----------------------------------	------------------

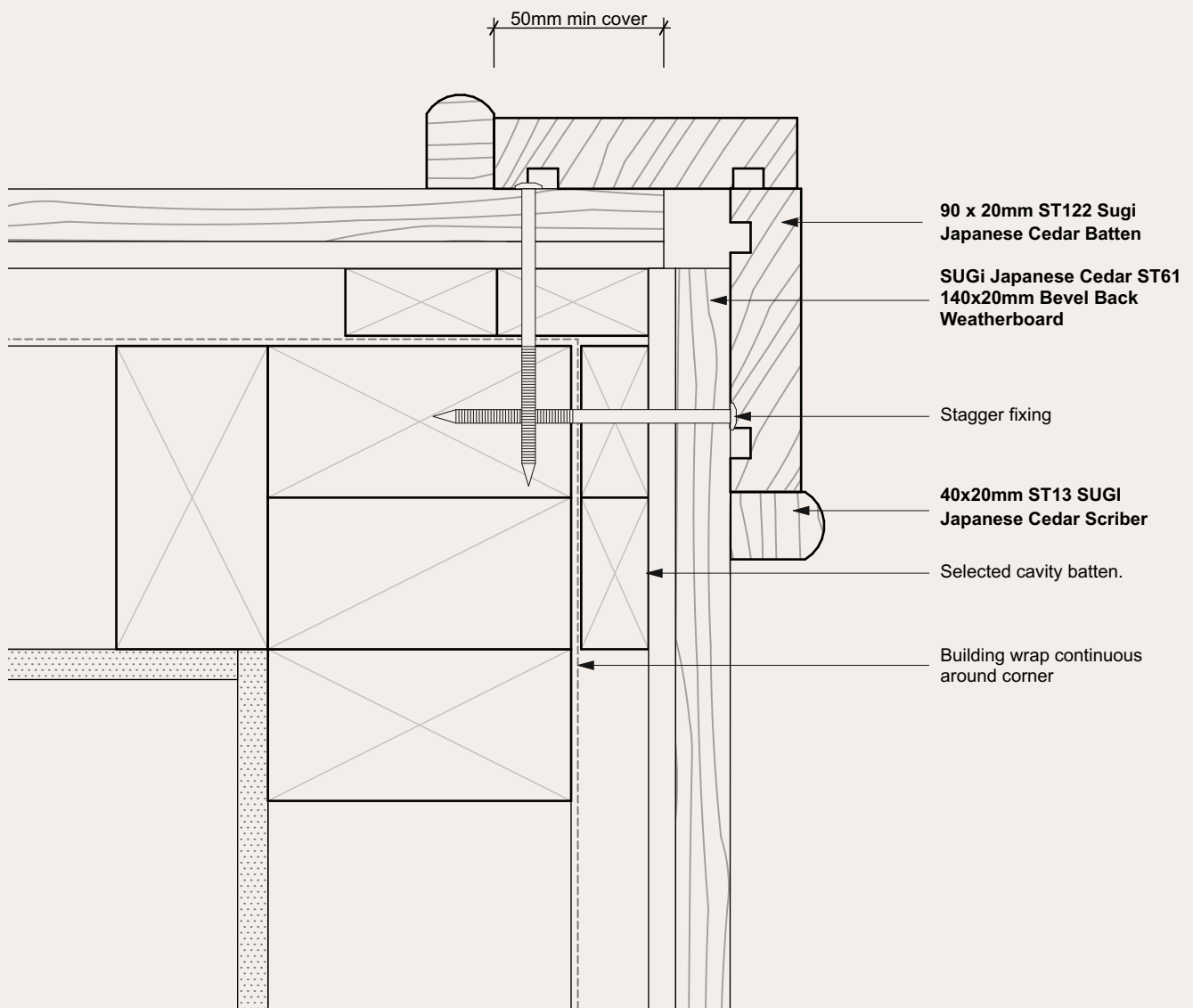

NOTES

- All nail fixings pre-drilled min. 1mm diameter smaller than nail gauge.
- All Sugi NZ Ltd timber products to be pre-coated and cut ends and edges and all fresh cut surfaces double coated and sealed before fixing. All timbers are to be coated as per Dryden's specification.
- All corner flashings to be 75 x 75mm to suit all wind zones. All flashings to have hemmed edges to NZBC E2/AS1.
- Avoid contact in seaspray zones or corrosion zone D between CCA treated timber and metal flashings. Refer NZBC E2/AS1 Table 21

	<p>DRAWING Bevel Back Weatherboard System External Box Corner Detail</p>	<p>SCALE 1:2 @ A4</p>	<p>ISSUE DATE 19-03-2026</p>	<p>27</p>
--	---	-----------------------	------------------------------	------------------

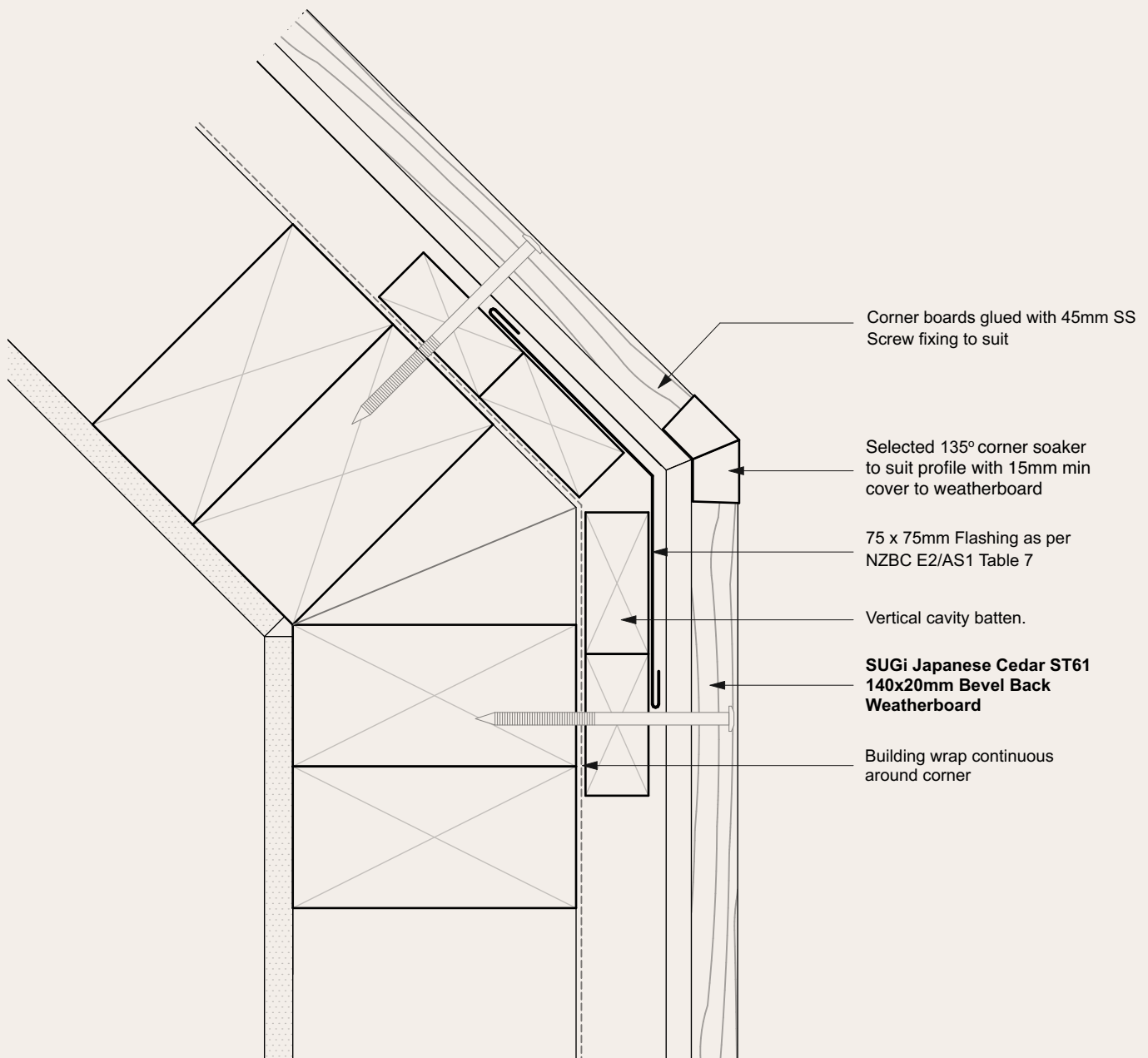

NOTES

- All nail fixings pre-drilled min. 1mm diameter smaller than nail gauge.
- All Sugi NZ Ltd timber products to be pre-coated and cut ends and edges and all fresh cut surfaces double coated and sealed before fixing. All timbers are to be coated as per Dryden's specification.
- All corner flashings to be 75 x 75mm to suit all wind zones. All flashings to have hemmed edges to NZBC E2/AS1.
- Avoid contact in seaspray zones or corrosion zone D between CCA treated timber and metal flashings. Refer NZBC E2/AS1 Table 21

	<p>DRAWING</p>	<p>Bevel Back Weatherboard System 135 Degree External Corner Detail</p>	<p>SCALE 1:2 @ A4</p>	<p>ISSUE DATE 19-03-2026</p>	<p>28</p>
--	----------------	--	---------------------------	----------------------------------	------------------

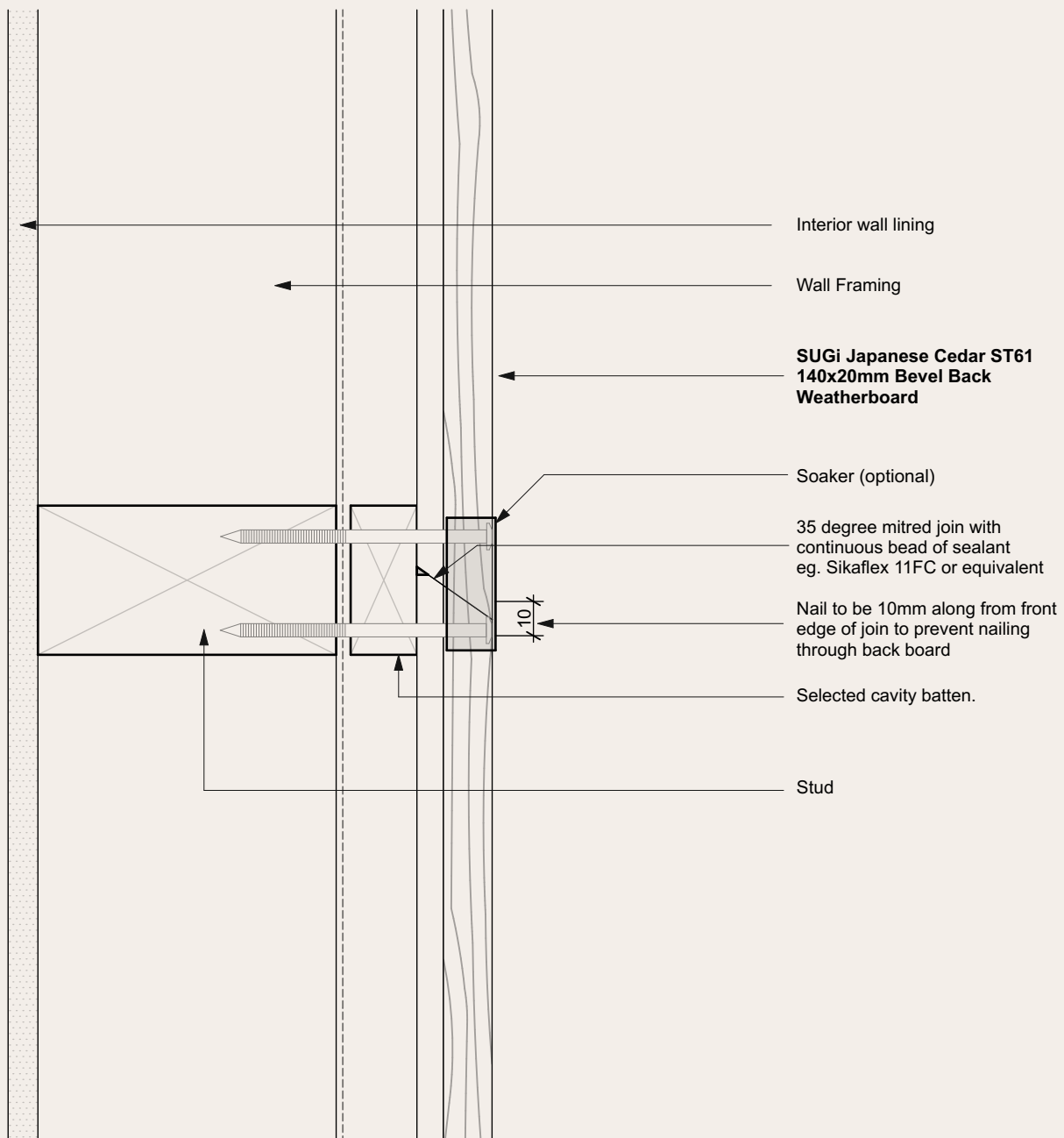

NOTES

- All nail fixings pre-drilled min. 1mm diameter smaller than nail gauge.
- All Sugi NZ Ltd timber products to be pre-coated and cut ends and edges and all fresh cut surfaces double coated and sealed before fixing. All timbers are to be coated as per Dryden's specification.
- All corner flashings to be 75 x 75mm to suit all wind zones. All flashings to have hemmed edges to NZBC E2/AS1.
- Avoid contact in seaspray zones or corrosion zone D between CCA treated timber and metal flashings. Refer NZBC E2/AS1 Table 21

	<p>DRAWING Bevel Back Weatherboard System Scarf Joint Detail</p>	<p>SCALE 1:2 @ A4</p>	<p>ISSUE DATE 19-03-2026</p>	<p>29</p>
--	--	---------------------------	----------------------------------	------------------

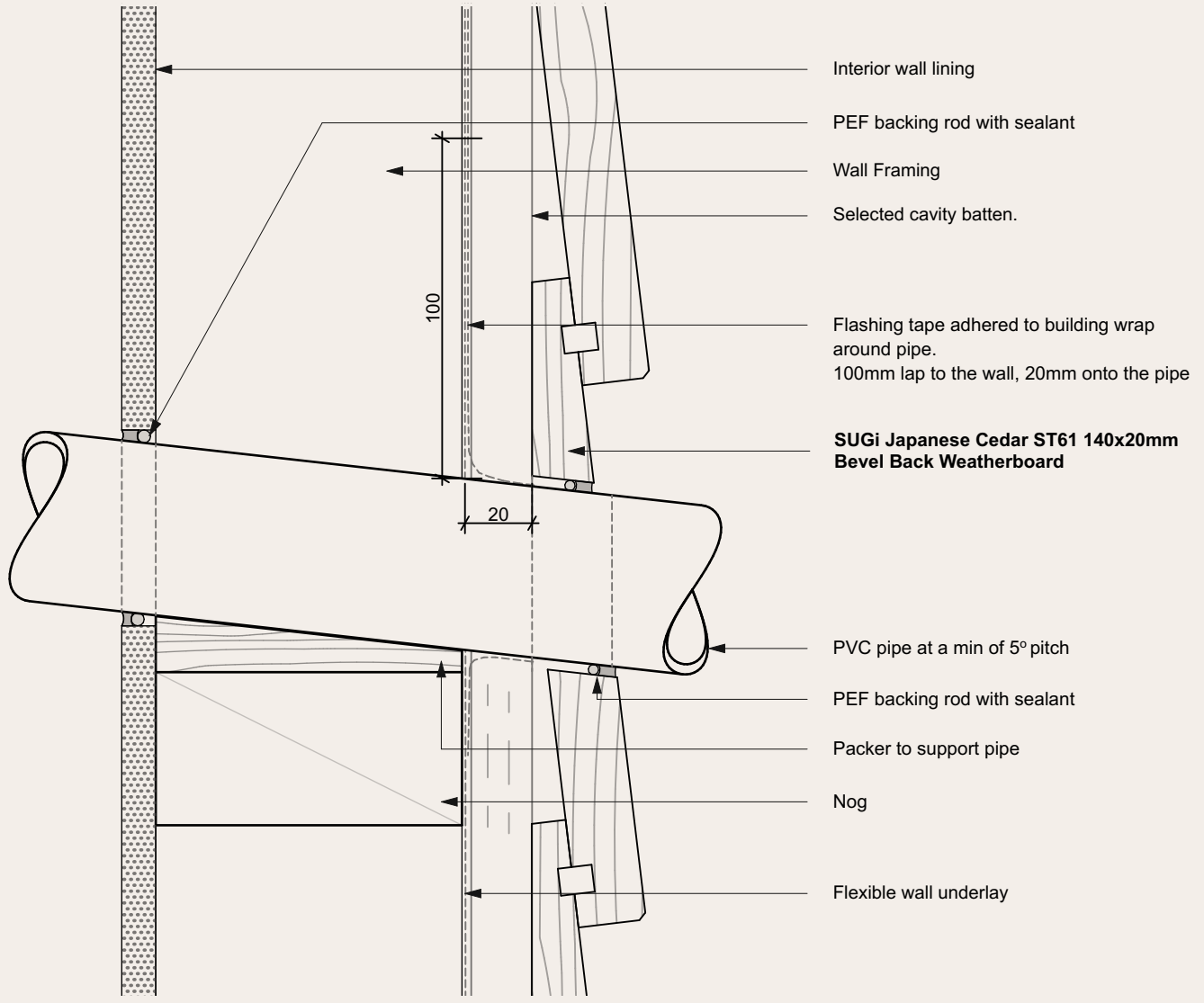

NOTES

- All nail fixings pre-drilled min. 1mm diameter smaller than nail gauge.
- All Sugi NZ Ltd timber products to be pre-coated and cut ends and edges and all fresh cut surfaces double coated and sealed before fixing. All timbers are to be coated as per Dryden's specification.
- All corner flashings to be 75 x 75mm to suit all wind zones. All flashings to have hemmed edges to NZBC E2/AS1.
- Avoid contact in seaspray zones or corrosion zone D between CCA treated timber and metal flashings. Refer NZBC E2/AS1 Table 21

	<p>DRAWING Bevel Back Weatherboard System Pipe Penetration Detail</p>	<p>SCALE 1:2 @ A4</p>	<p>ISSUE DATE 19-03-2026</p>	<p>30</p>
--	--	---------------------------	----------------------------------	------------------

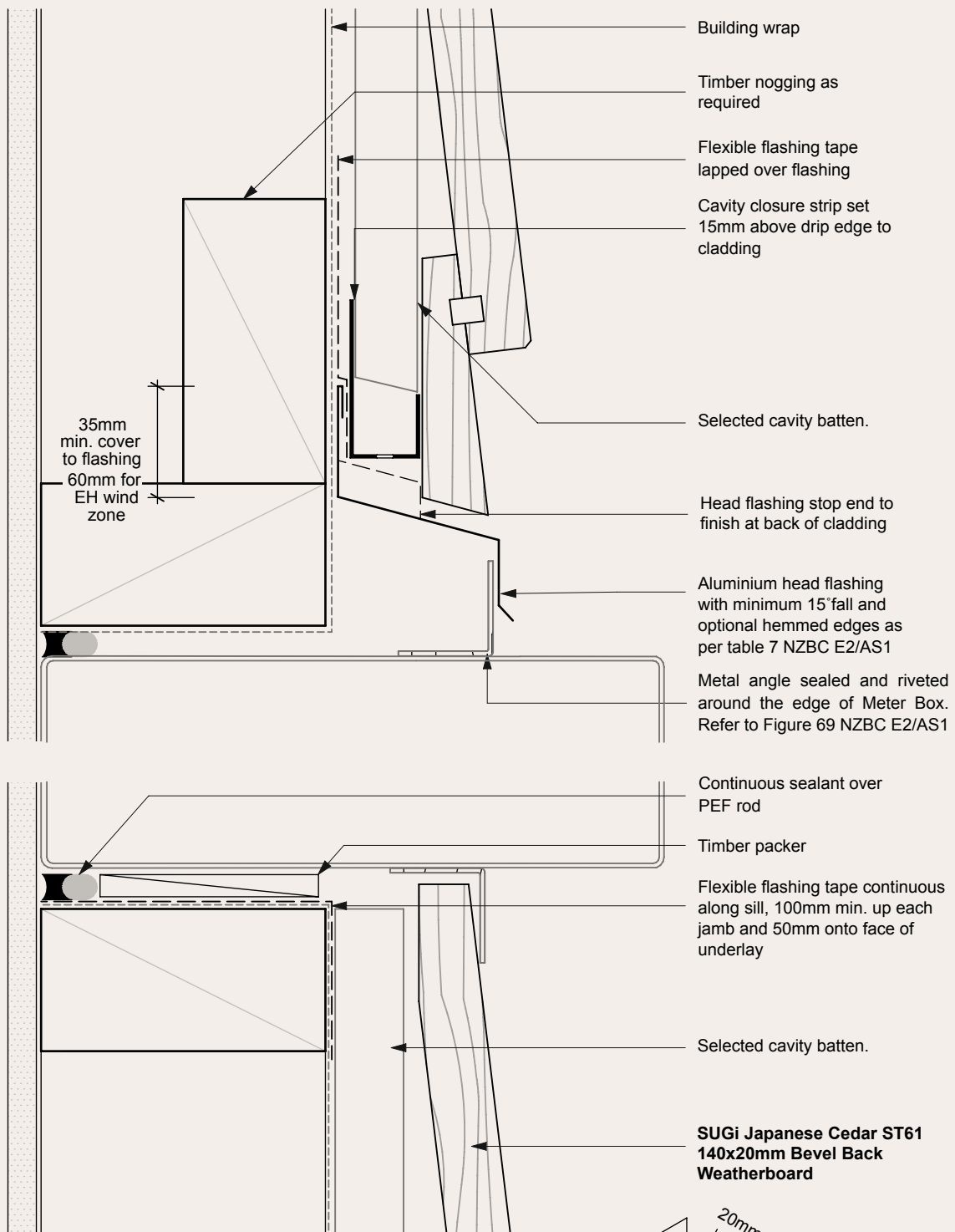

NOTES

- All nail fixings pre-drilled min. 1mm diameter smaller than nail gauge.
- All Sugi NZ Ltd timber products to be pre-coated and cut ends and edges and all fresh cut surfaces double coated and sealed before fixing. All timbers are to be coated as per Dryden's specification.
- All corner flashings to be 75 x 75mm to suit all wind zones. All flashings to have hemmed edges to NZBC E2/AS1.
- Avoid contact in seaspray zones or corrosion zone D between CCA treated timber and metal flashings. Refer NZBC E2/AS1 Table 21

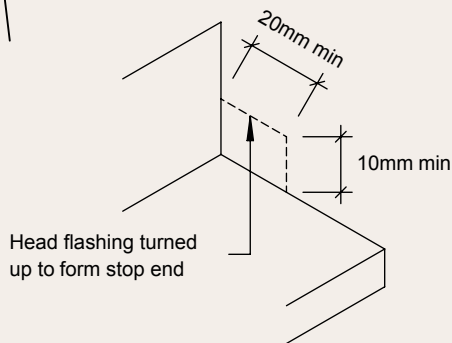

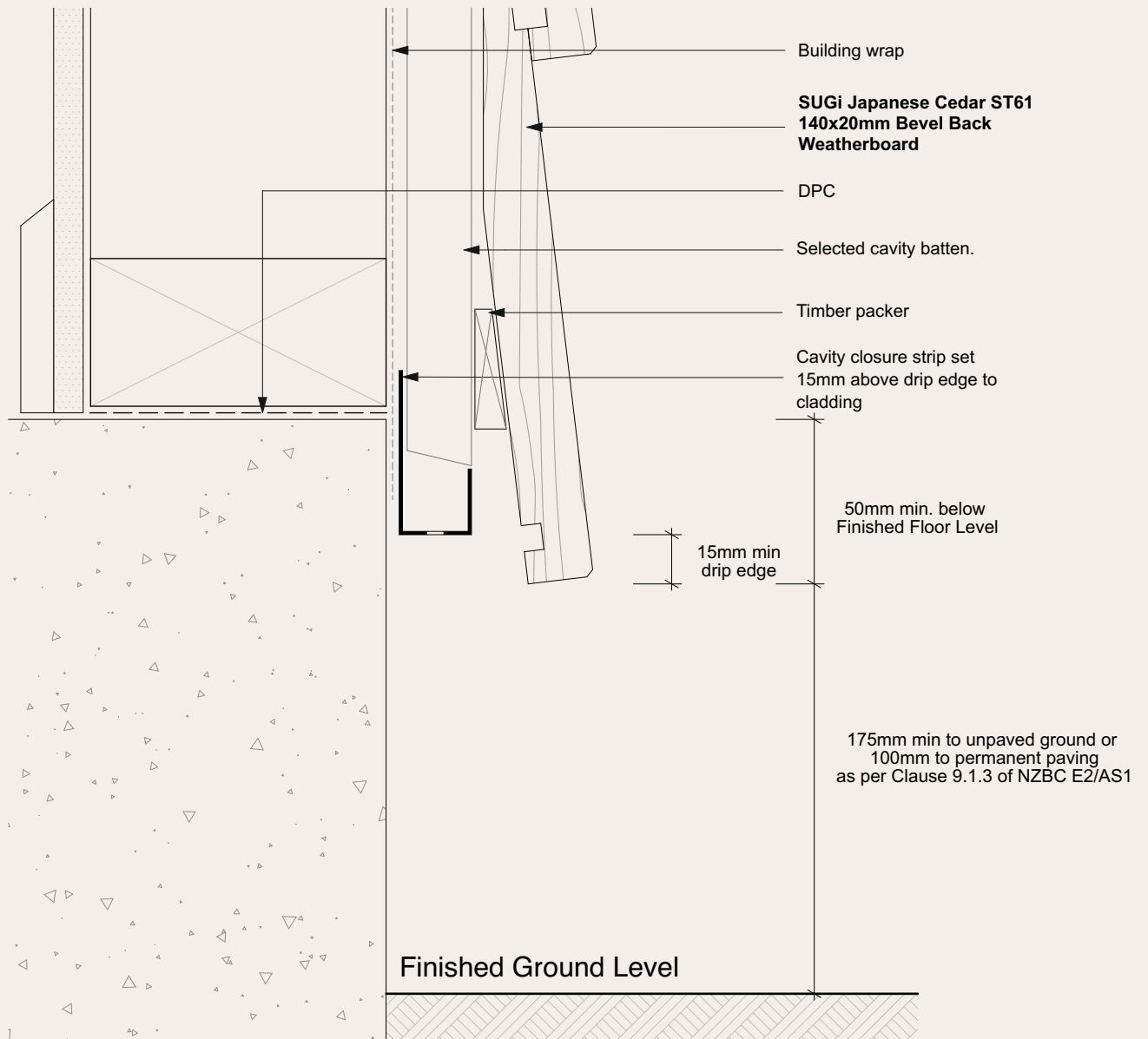

NOTES

- All nail fixings pre-drilled min. 1mm diameter smaller than nail gauge.
- All Sugi NZ Ltd timber products to be pre-coated and cut ends and edges and all fresh cut surfaces double coated and sealed before fixing. All timbers are to be coated as per Dryden's specification.
- All corner flashings to be 75 x 75mm to suit all wind zones. All flashings to have hemmed edges to NZBC E2/AS1.
- Avoid contact in seaspray zones or corrosion zone D between CCA treated timber and metal flashings. Refer NZBC E2/AS1 Table 21

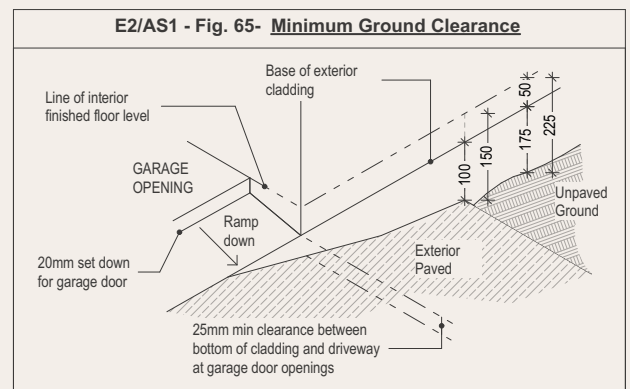

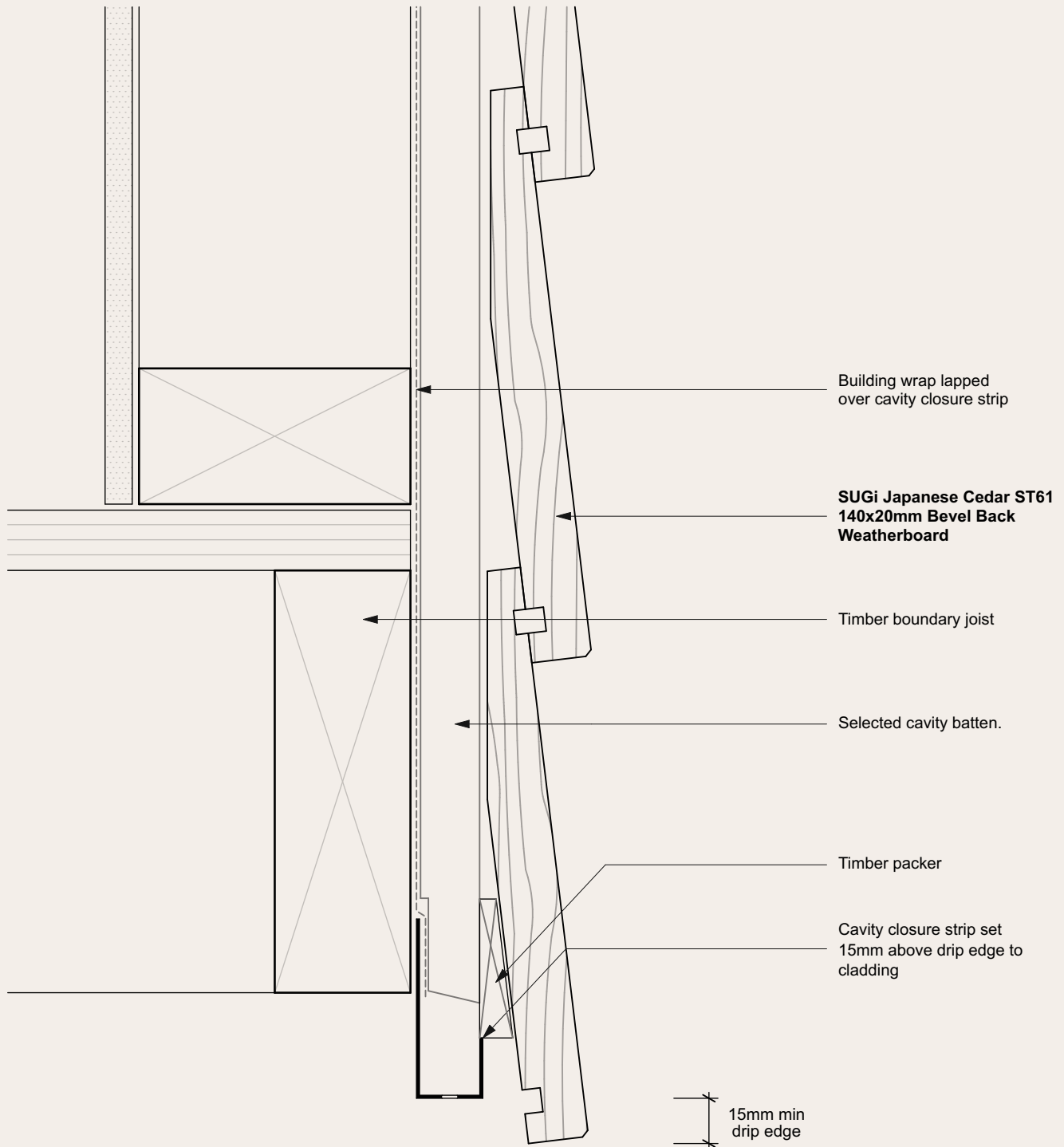

NOTES

- All nail fixings pre-drilled min. 1mm diameter smaller than nail gauge.
- All Sugi NZ Ltd timber products to be pre-coated and cut ends and edges and all fresh cut surfaces double coated and sealed before fixing. All timbers are to be coated as per Dryden's specification.
- All corner flashings to be 75 x 75mm to suit all wind zones. All flashings to have hemmed edges to NZBC E2/AS1.
- Avoid contact in seaspray zones or corrosion zone D between CCA treated timber and metal flashings. Refer NZBC E2/AS1 Table 21

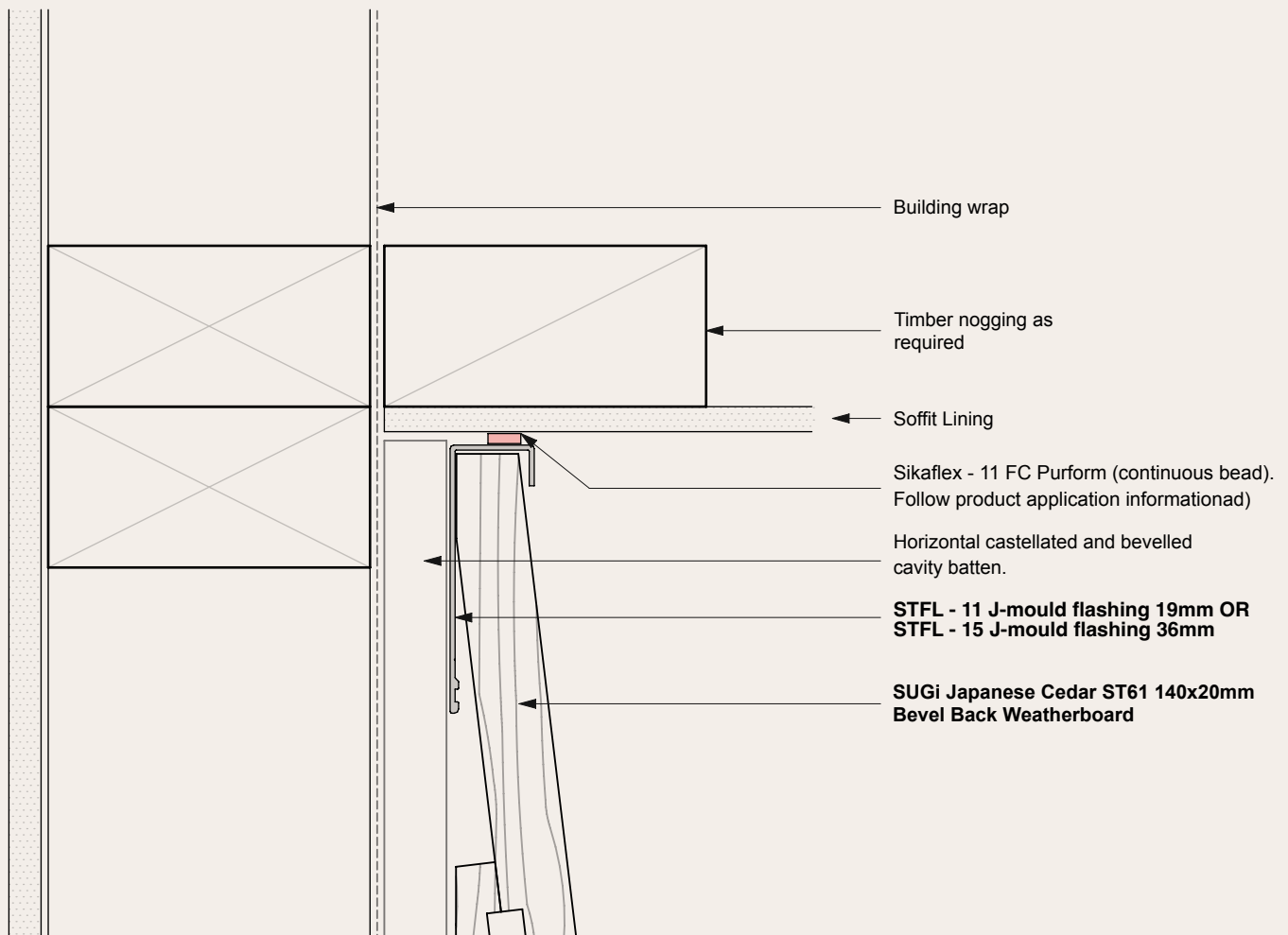

NOTES

- All nail fixings pre-drilled min. 1mm diameter smaller than nail gauge.
- All Sugi NZ Ltd timber products to be pre-coated and cut ends and edges and all fresh cut surfaces double coated and sealed before fixing. All timbers are to be coated as per Dryden's specification.
- All corner flashings to be 75 x 75mm to suit all wind zones. All flashings to have hemmed edges to NZBC E2/AS1.
- Avoid contact in seaspray zones or corrosion zone D between CCA treated timber and metal flashings. Refer NZBC E2/AS1 Table 21

	<p>DRAWING Bevel Back Weatherboard System Soffit Detail Overhang</p>	<p>SCALE 1:2 @ A4</p>	<p>ISSUE DATE 19-03-2026</p>	<p>34</p>
--	--	---------------------------	----------------------------------	------------------

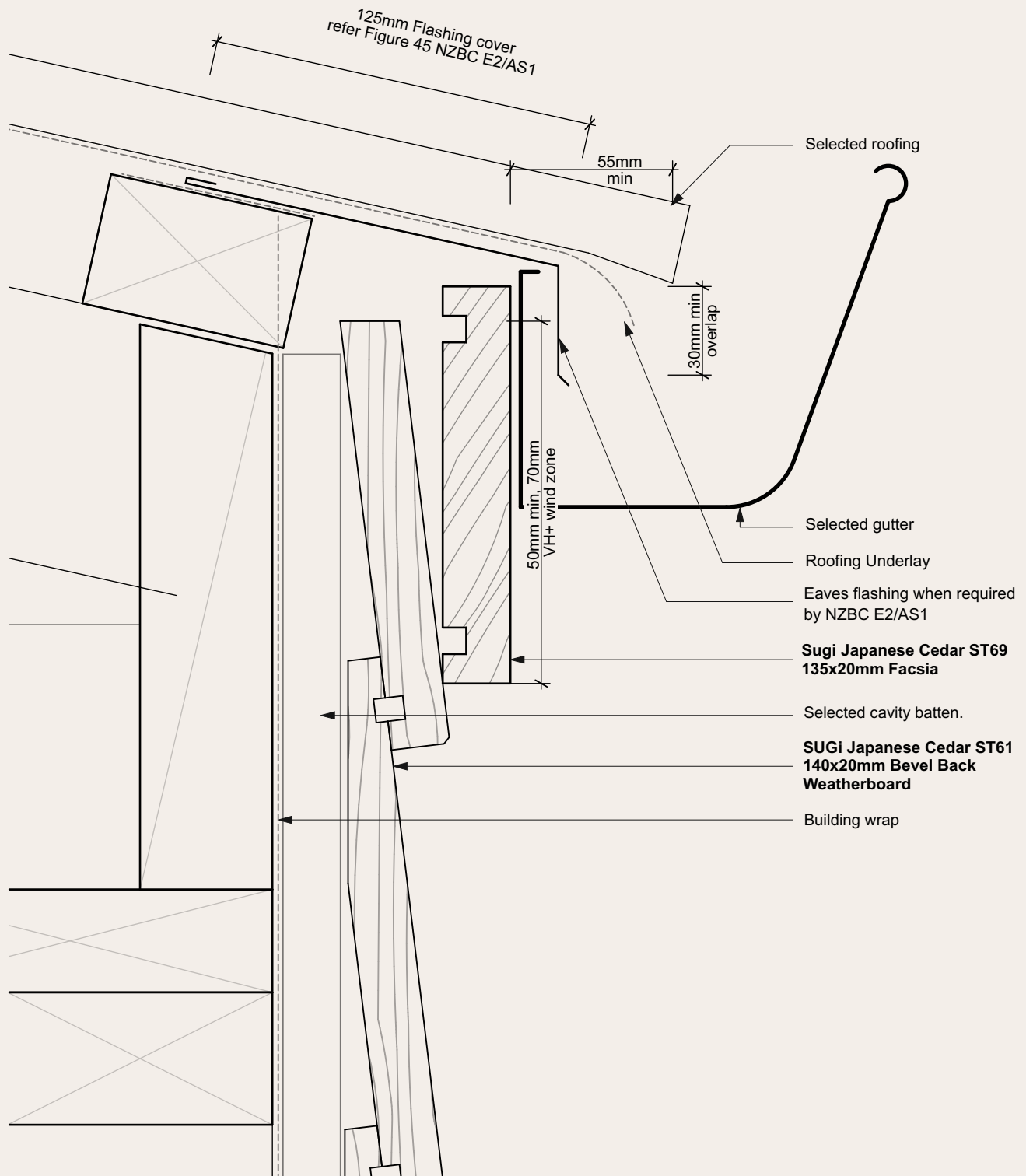

NOTES

- All nail fixings pre-drilled min. 1mm diameter smaller than nail gauge.
- All Sugi NZ Ltd timber products to be pre-coated and cut ends and edges and all fresh cut surfaces double coated and sealed before fixing. All timbers are to be coated as per Dryden's specification.
- All corner flashings to be 75 x 75mm to suit all wind zones. All flashings to have hemmed edges to NZBC E2/AS1.
- Avoid contact in seaspray zones or corrosion zone D between CCA treated timber and metal flashings. Refer NZBC E2/AS1 Table 21

	<p>DRAWING Bevel Back Weatherboard System Eaves Detail</p>	<p>SCALE 1:2 @ A4</p>	<p>ISSUE DATE 19-03-2026</p>	<p>35</p>
--	---	-----------------------	------------------------------	------------------

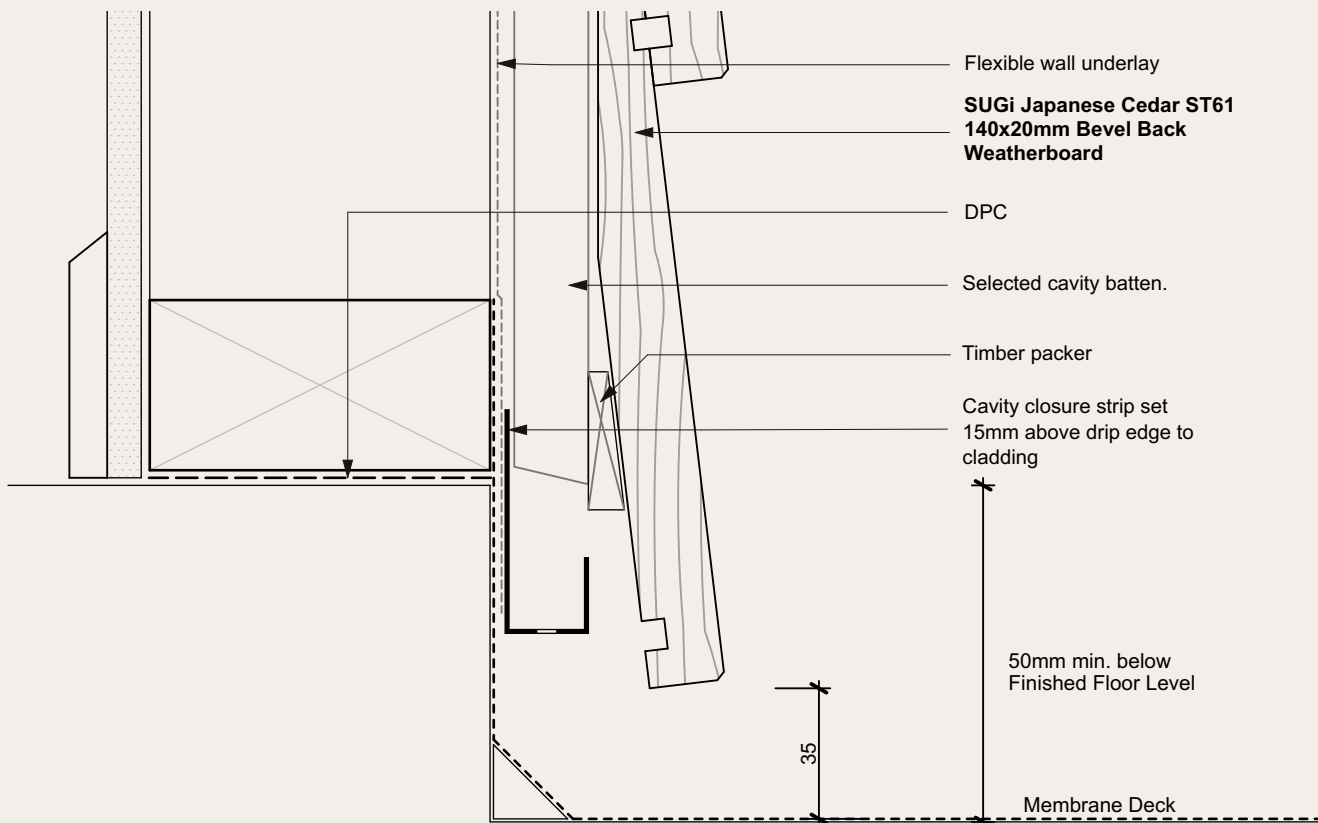

NOTES

- All nail fixings pre-drilled min. 1mm diameter smaller than nail gauge.
- All Sugi NZ Ltd timber products to be pre-coated and cut ends and edges and all fresh cut surfaces double coated and sealed before fixing. All timbers are to be coated as per Dryden's specification.
- All corner flashings to be 75 x 75mm to suit all wind zones. All flashings to have hemmed edges to NZBC E2/AS1.
- Avoid contact in seaspray zones or corrosion zone D between CCA treated timber and metal flashings. Refer NZBC E2/AS1 Table 21

	<p>DRAWING Bevel Back Weatherboard System</p> <p style="text-align: center;">Base to Membrane Detail</p>	<p>SCALE</p> <p>1:2 @ A4</p>	<p>ISSUE DATE</p> <p>19-03-2026</p>	<p>36</p>
---	--	------------------------------	-------------------------------------	------------------

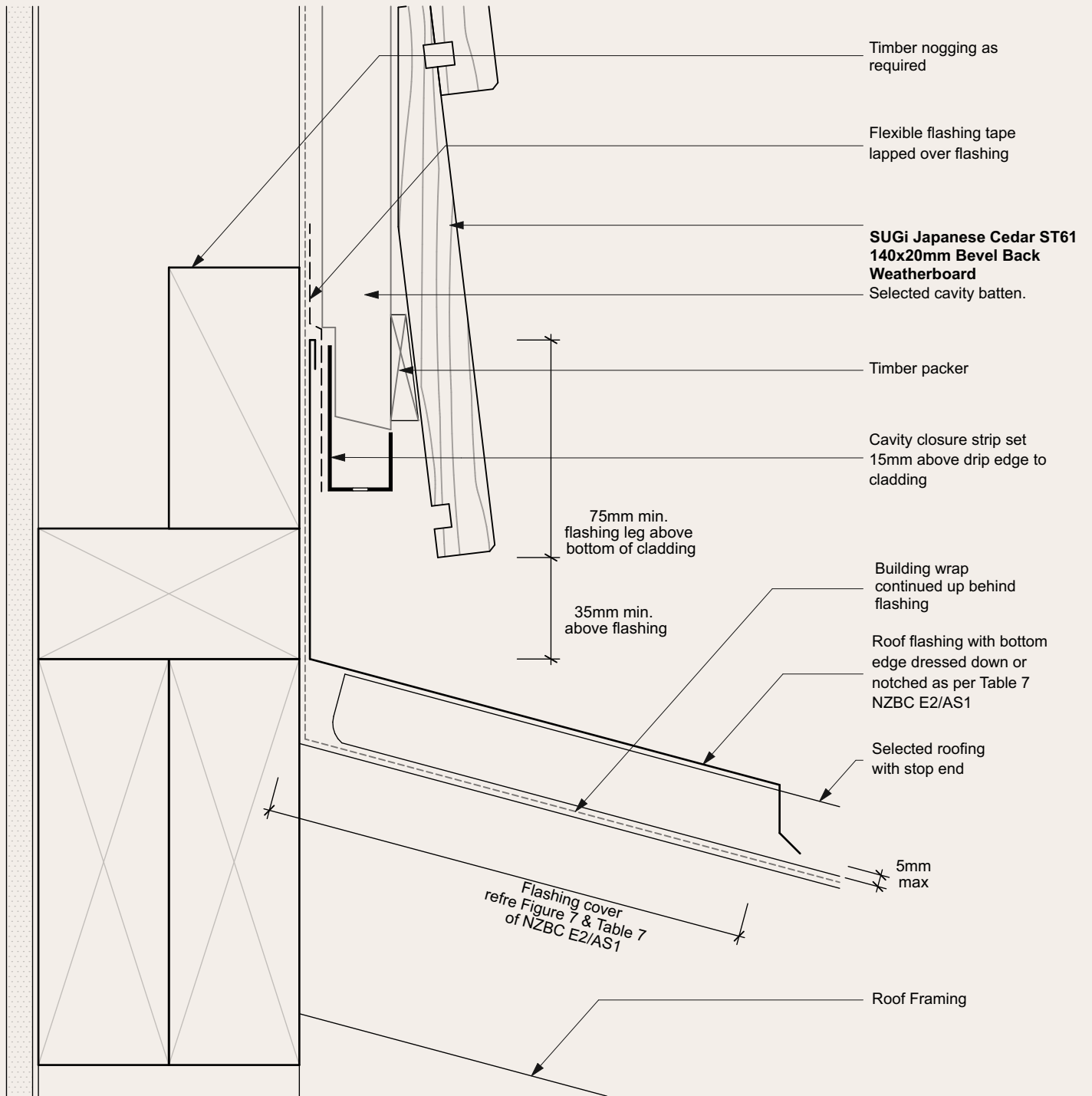

NOTES

- All nail fixings pre-drilled min. 1mm diameter smaller than nail gauge.
- All Sugi NZ Ltd timber products to be pre-coated and cut ends and edges and all fresh cut surfaces double coated and sealed before fixing. All timbers are to be coated as per Dryden's specification.
- All corner flashings to be 75 x 75mm to suit all wind zones. All flashings to have hemmed edges to NZBC E2/AS1.
- Avoid contact in seaspray zones or corrosion zone D between CCA treated timber and metal flashings. Refer NZBC E2/AS1 Table 21

	<p>DRAWING</p>	<p>Bevel Back Weatherboard System Roof/Wall Junction Detail</p>	<p>SCALE 1:2 @ A4</p>	<p>ISSUE DATE 19-03-2026</p>	<p>37</p>
--	----------------	--	---------------------------	----------------------------------	------------------

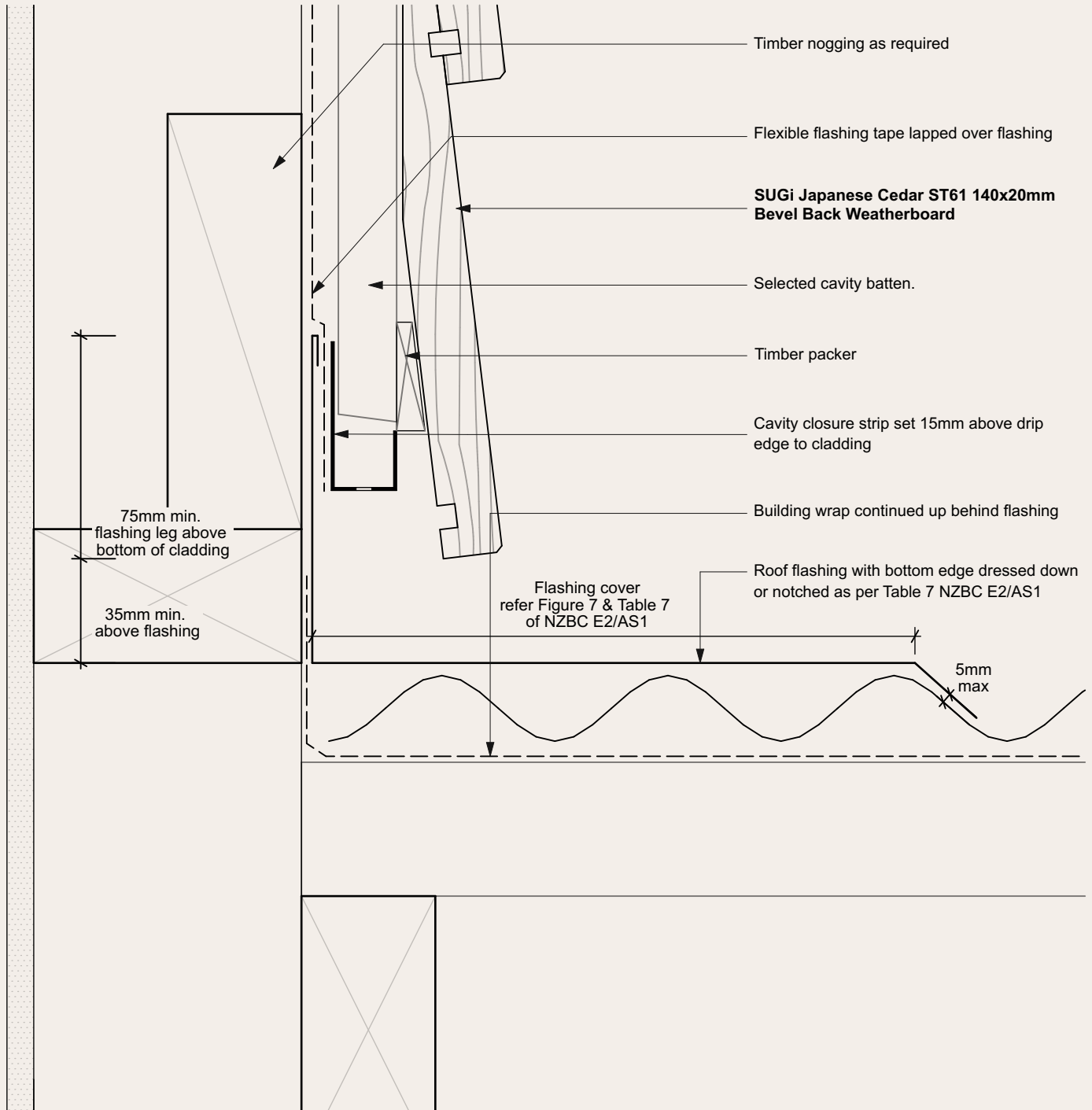

NOTES

- All nail fixings pre-drilled min. 1mm diameter smaller than nail gauge.
- All Sugi NZ Ltd timber products to be pre-coated and cut ends and edges and all fresh cut surfaces double coated and sealed before fixing. All timbers are to be coated as per Dryden's specification.
- All corner flashings to be 75 x 75mm to suit all wind zones. All flashings to have hemmed edges to NZBC E2/AS1.
- Avoid contact in seaspray zones or corrosion zone D between CCA treated timber and metal flashings. Refer NZBC E2/AS1 Table 21

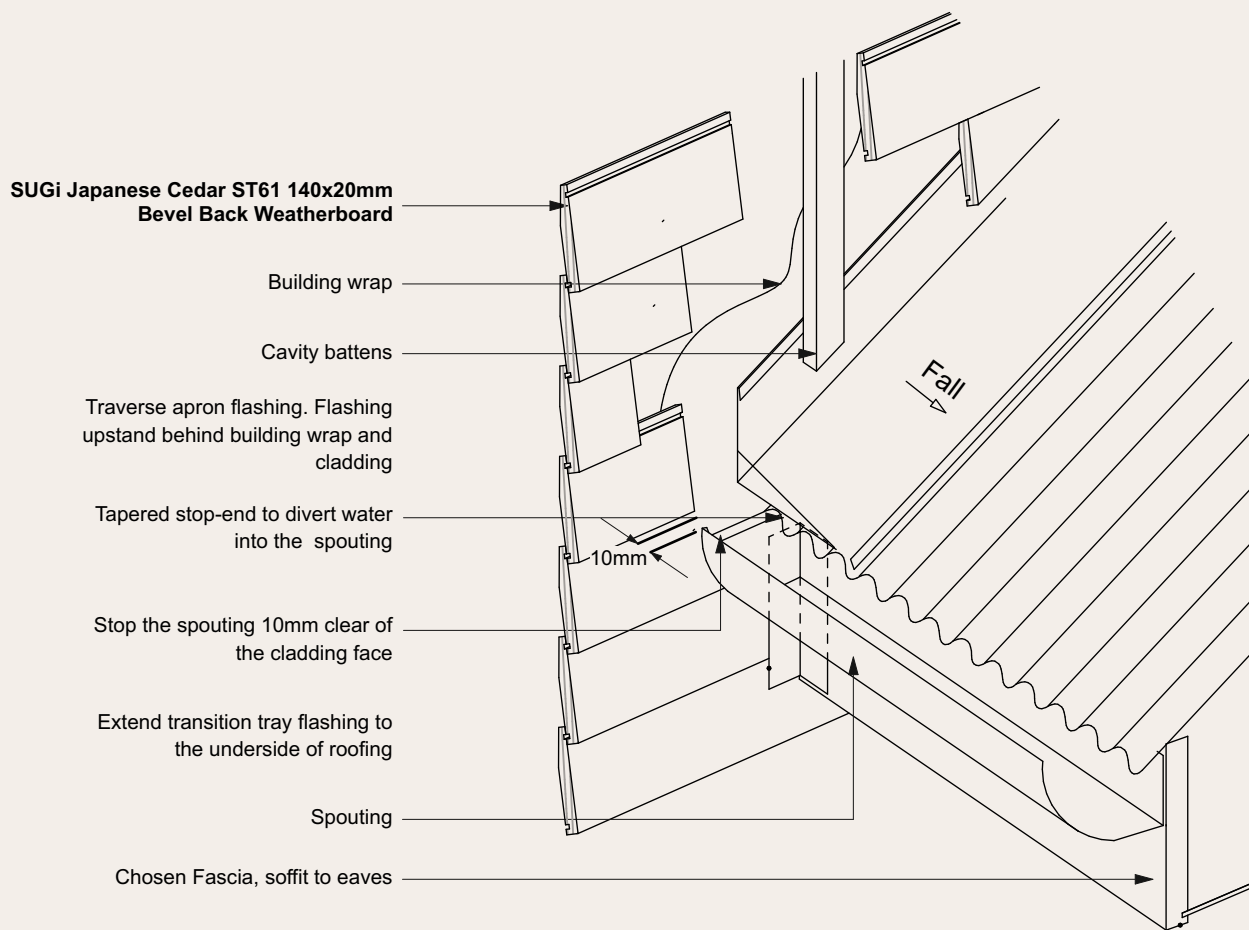

NOTES

- All nail fixings pre-drilled min. 1mm diameter smaller than nail gauge.
- All Sugi NZ Ltd timber products to be pre-coated and cut ends and edges and all fresh cut surfaces double coated and sealed before fixing. All timbers are to be coated as per Dryden's specification.
- All corner flashings to be 75 x 75mm to suit all wind zones. All flashings to have hemmed edges to NZBC E2/AS1.
- Avoid contact in seaspray zones or corrosion zone D between CCA treated timber and metal flashings. Refer NZBC E2/AS1 Table 21

	DRAWING Bevel Back Weatherboard System Roof Kickout Detail	SCALE 1:2 @ A4	ISSUE DATE 19-03-2026	39
--	---	-------------------	--------------------------	-----------

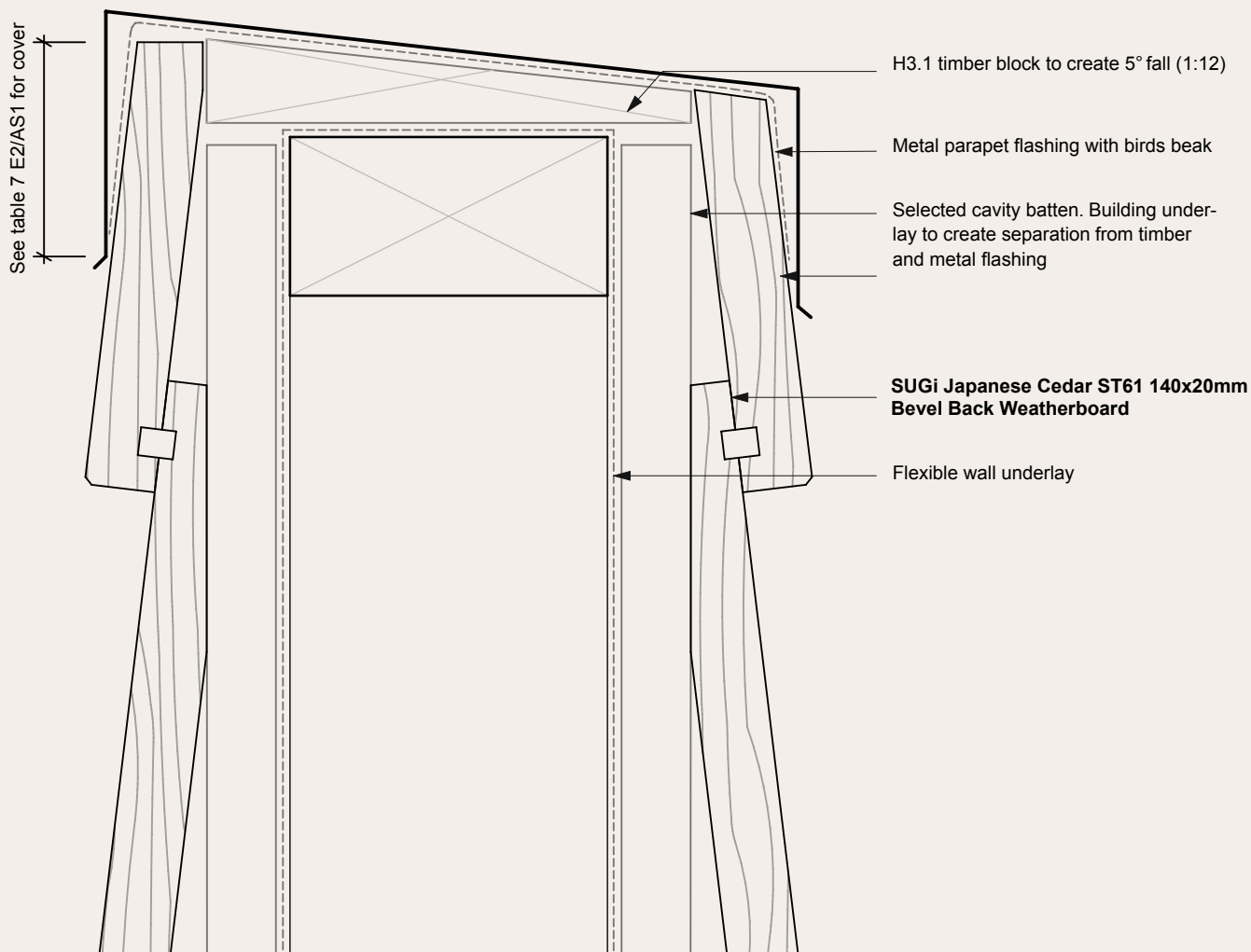

NOTES

- All nail fixings pre-drilled min. 1mm diameter smaller than nail gauge.
- All Sugi NZ Ltd timber products to be pre-coated and cut ends and edges and all fresh cut surfaces double coated and sealed before fixing. All timbers are to be coated as per Dryden's specification.
- All corner flashings to be 75 x 75mm to suit all wind zones. All flashings to have hemmed edges to NZBC E2/AS1.
- Avoid contact in seaspray zones or corrosion zone D between CCA treated timber and metal flashings. Refer NZBC E2/AS1 Table 21

	<p>DRAWING Bevel Back Weatherboard System</p> <p style="text-align: center;">Parapet Detail</p>	<p>SCALE</p> <p>1:2 @ A4</p>	<p>ISSUE DATE</p> <p>19-03-2026</p>	<p>40</p>
---	---	------------------------------	-------------------------------------	------------------

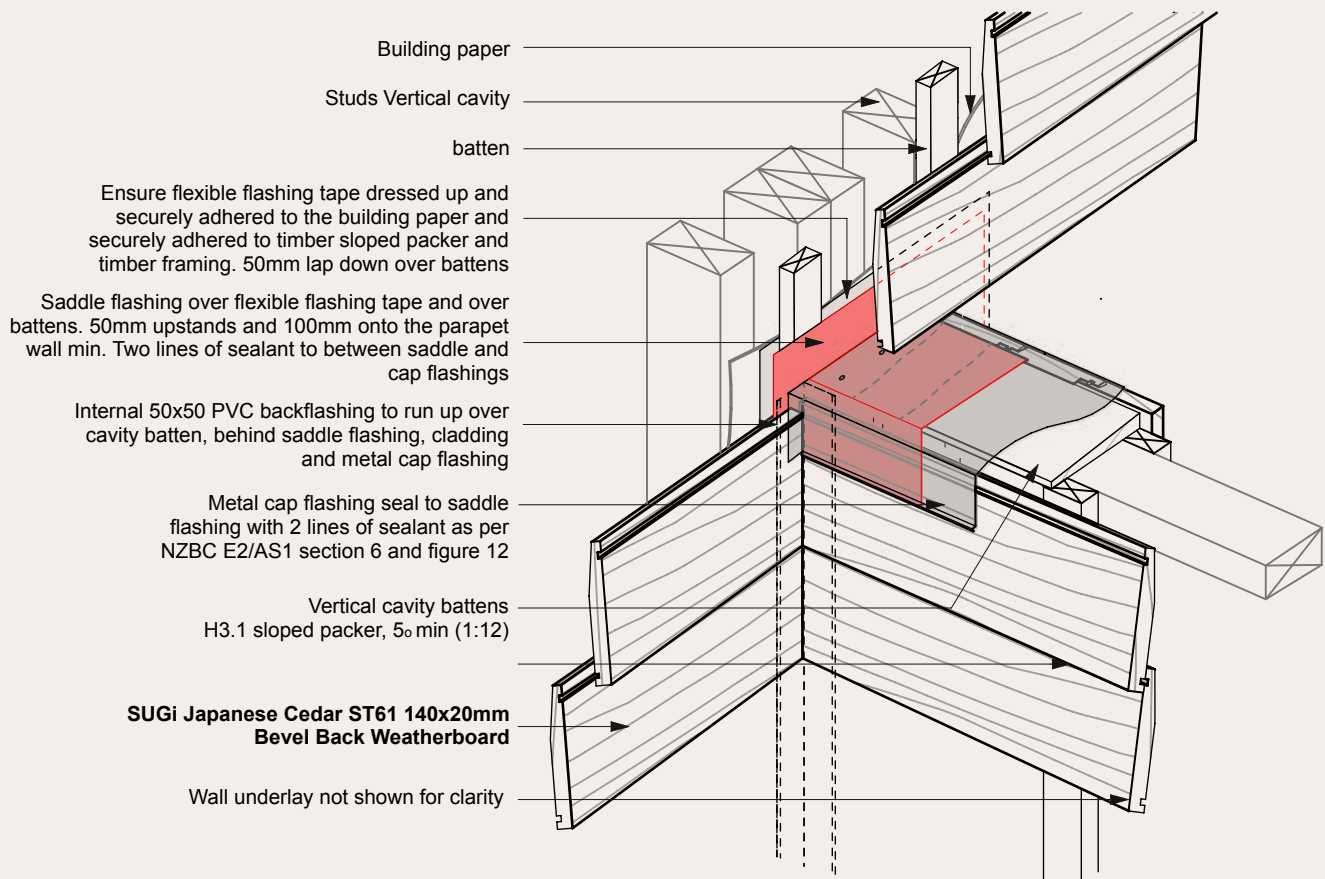

See NZBC E2/AS1 Figure 12 for step by step detail detail to be read in conjunction with Parapet Detail

NOTES

- All nail fixings pre-drilled min. 1mm diameter smaller than nail gauge.
- All Sugi NZ Ltd timber products to be pre-coated and cut ends and edges and all fresh cut surfaces double coated and sealed before fixing. All timbers are to be coated as per Dryden's specification.
- All corner flashings to be 75 x 75mm to suit all wind zones. All flashings to have hemmed edges to NZBC E2/AS1.
- Avoid contact in seaspray zones or corrosion zone D between CCA treated timber and metal flashings. Refer NZBC E2/AS1 Table 21

	<p>DRAWING</p>	<p>Bevel Back Weatherboard System Parapet Balustrade Detail</p>	<p>SCALE 1:2 @ A4</p>	<p>ISSUE DATE 19-03-2026</p>	<p>41</p>
--	----------------	--	---------------------------	----------------------------------	------------------

Timber Weatherboard Handling & Storage

All SUGi timber weatherboards are Kiln dried and oil coated to site and care must be taken to ensure a correct installation process can take place.

Kiln dried profiled SUGi timber weatherboards are machined to profile at a moisture content between 12-16% therefore depending on the atmospheric conditions can take up additional moisture upon arriving at the site depending on site specific handling and storage of the product

Timber must be in storage out of the sun, ideally on top of a concrete substrate with a non permeable vapour placed above the concrete substrate, bearers of 200mm height are then to be laid and timber product placed on top of bearers. Additional wrap should be placed over the entire parcel to assist with slowing down the moisture uptake and release until timber is used.

Please read our installation details to ensure correct installation is carried out.

Producer's Statement

Japanese Cedar heartwood (*Cryptomeria Japonica*) - exterior timber cladding

All Japanese Cedar (*Cryptomeria Japonica*) – exterior timber cladding supplied by Sugi NZ Ltd is supplied in select grades either clear grade or select grade, both heart grade timber with a durability class similar to H3.1 (as per the NZ Building code NZS3602).

Natural imperfections and visual defects are permissible and should be considered as typical to this species.

Individual boards that carry any minor inclusion of defect or sap content are to be graded to the back of the board and will not exceed 5% of the total volume of timber supplied.

In some instances further grading and docking are required to further eliminate potential defect that may not be acceptable in the end use, this is to be carried out within 7 days of the timbers arrival to site.

15 Year Warranty

Limited warranty for Japanese Cedar timber supplied by SUGI NZ

SUGI NZ warrants to the building owner (the 'Owner') into which SUGI (the 'product') has been placed. This warrant guarantees that the product will resist damage caused by fungal decay for a total of 15 years from the supply date, thereby ensuring that it is not Structurally Unfit for its original purpose. This guarantee is subject to the following terms and conditions:

Conditions of Warranty:

By definition, Structurally Unfit refers to the inability of the Product to perform its intended function for which it was originally acquired and used. This inability is produced solely through the result of fungal decay, where the product has been used in an appropriate application, in accordance with the terms and conditions of this warranty and not exceeding its reasonable limitations.

This warranty is intended to benefit the first Owner, while they are the owner of the property.

It is applicable to both residential and light commercial applications that stand at least 300mm above ground level, or as otherwise stated in technical literature provided by SUGI NZ.

The product is to be proved as a genuine SUGI NZ product. This requires the production of the proof of date, purchase and packet number from which the material came from.

The way in which the product has been handled, fixed and maintained must be in accordance with the appropriate guidelines in force at the time i.e. Installation instructions or the appropriate current SUGI Technical Data Sheet published by SUGI NZ Limited.

The product must be protected on all sides and ends, and maintained with an appropriate coating surface protection system.

The Owner must make a warranty claim within 6 months of discovery of the relevant fungal decay.

Exclusions of Warranty:

- The warranty will not cover any claims made against the Owner by any occupier of the property.
- The Product being placed in fresh, salt water or ground contact conditions.
- The Product being removed from its original installation and reused at a new location.
- Any degrade caused by poor installation or maintenance, including the accumulation of dirt and other organic matter, or by a material change in the installation environment i.e. where the product is 'in effect' being unnecessarily subjected to in-ground contact conditions, such as those created by water or soil entrapment under planters or similar objects or conditions.

-
- Failure that results from the Product being used for any purpose that it was not designed for.
 - Direct or indirect corrosion of metal fasteners or hardware, used in conjunction with the product.
 - Weathering of the Product, including, but not limited to, splitting, checking, swelling, raised grain, twisting warping, shrinking, de-lamination of any laminated Product, or any other physical property of the wood.
 - 'Fungal Decay,' as used in the warranty, refers to the wood destroying fungi that degenerate and feed on the wood cell walls. Staining and mould fungi associated with the weathering of the product is excluded.

Transferability of Warranty:

This warranty is only of benefit to the first Owner, while they are the owner of the property. It is not transferable or assignable to any other person, including any builder or occupier of the property.

Undertaking:

The warranty consists of the cost of re-supply, by SUGI NZ Limited, of Product that is proven to have failed as a result of fungal decay, FREE OF CHARGE. SUGI NZ may either replace the product with the same or similar product, or offer a full refund of the original price at the Owner's discretion. The warranty does not cover the removal costs or reinstatement of such components or consequential costs, or any loss resulting from failure of the component. Prior to removal, the Owner must authorize a Product inspection by SUGI NZ and/or their representatives.

Statutory Rights:

This warranty is in addition to the purchaser's normal statutory rights. The warranties are from manufacturer to consumer/buyer. However, the authorised retailer from where the goods were purchased from should be the initial contact, if a complaint needs to be raised. The complaint should be made in writing/e-mail, and must include the proof of purchase, which comprises of the original invoice and this completed warranty document.

IOKA Exterior Oils

1. IDENTIFICATION OF THE SUBSTANCE AND SUPPLIER

PRODUCT NAME	iOKA Exterior Oil
RECOMMENDED USES	Coating exterior cladding, timberwork and decks
SUPPLIER	NZ Natural Timber Co Ltd, 68 Marsden Bay Drive, Marsden, Whangarei 0118, New Zealand Phone 027 6600095
EMERGENCY CONTACT	In emergency dial 111 then ask for Fire, Ambulance or Police as required. In case of poisoning phone National Poisons Dunedin 0800 764 766

2. HAZARDS IDENTIFICATION

DANGER

KEEP OUT OF REACH OF CHILDREN

Read Label Before Use and Read Safety Data Sheet Before Use

HSNO Classification 3.1D 6.1E, 6.3A, 6.5B, 9.1C

Warning

Combustible Liquid. May be harmful if swallowed, on skin, and if enters airways. Irritating to eyes and skin. May cause sensitisation by skin contact. Toxic to aquatic organisms, may cause long-term adverse effects in the aquatic environment.

Precautions

Avoid release to the environment. If medical advice is needed, have product container or label at hand. Keep out of the reach of children. Read label before use. Keep away from heat/sparks/open flames/hot surfaces. No smoking. Wear protective gloves/protective clothing/eye protection/face protection

3. COMPOSITION AND INFORMATION ON INGREDIENTS

NAME	CAS NUMBER	PROPORTION
Alkanes	90622-58-5	45 – 55%
Zirconium Drier	94581-21-2	0.1 – 1.0%
Zinc Drier	84418-50-8	0.1 – 1.0%
Manganese Drier	37449-19-7	0.1 – 1.0%
2-(2-butoxyethoxy)ethanol	112-34-5	0.1 – 1.0%
Terbutryn	886-50-0	0.03 – 0.15%
2-Octyl-2H-isothiazol-3-one	26530-20-1	0.03 – 0.15%

Plus other ingredients in quantities that are not deemed to be hazardous

4. FIRST AID MEASURES

INHALATION

Remove victim from area of exposure- avoid becoming a casualty. Remove contaminated clothing and loosen remaining clothing. Allow patient to assume most comfortable position and keep warm. Keep at rest until fully recovered. If patient finds breathing difficult and develops a bluish colouration of skin, ensure airways are clear of any obstruction and have a qualified person giving oxygen through a face mask. Apply artificial respiration if person is not breathing. Seek medical attention.

SKIN CONTACT

Wash off immediately with soap and plenty of water while removing all contaminated clothes and shoes. If skin irritation occurs get medical advice/ attention

EYE CONTACT

Remove contact lenses. Rinse immediately with plenty of water, also under the eyelids, for at least 15 minutes. Obtain medical attention.

INGESTION

Do NOT induce vomiting. Rinse mouth. Drink plenty of water. Obtain medical attention.

IF EXPOSED OR CONCERNED

Get medical advice/attention.

SYMPTOMS AND EFFECTS, ACUTE AND DELAYED, FROM EXPOSURE

EYE CONTACT causes severe irritation and may cause burns.

SKIN CONTACT causes irritation. Prolonged contact may cause dermatitis, sensitization, and/or burns.

INHALATION causes slight nose and throat irritation, at high concentrations, cough. In case of repeated or prolonged exposure, risk of sore throat, nose bleeds, chronic bronchitis.

INGESTION Small amounts of liquid aspirated into the lungs during ingestion, or from vomiting, may cause chemical pneumonitis, or pulmonary oedema. Ingesting large amounts of this product will result in headaches, nausea, dizziness and tracheal burning.

HEALTH HAZARD INFORMATION

Treat According to symptoms. Gastric lavage may be indicated if ingested. Do not wait for symptoms to develop. General measures should be taken to control acidosis and maintain urine output.

5. FIRE FIGHTING MEASURES

HAZARDS FROM COMBUSTION PRODUCTS

Combustible with toxic organic and metallic fumes.

PRECAUTIONS FOR FIRE FIGHTERS AND SPECIAL PROTECTIVE EQUIPMENT

Heating can cause expansion or decomposition of the material, which can lead to the containers exploding. If safe to do so, remove containers from the path of fire. Fire fighters to wear self-contained breathing apparatus and suitable protective clothing if risk of exposure to products of decomposition.

SUITABLE EXTINGUISHING MEDIA

Fine water spray, normal foam, dry agent (carbon dioxide, dry chemical powder).

6. ACCIDENTAL RELEASE MEASURES

EMERGENCY PROCEDURES

Eliminate every possible source of ignition. Isolate spill or leak area immediately. Clear area of all unprotected personnel. If contamination of sewers or waterways has occurred advise local emergency services.

Methods and materials for containment and clean up Absorb on fire retardant treated sawdust, diatomaceous earth, etc. Prevent entry of product into public water, sewers, or soil. Shovel up and dispose of at appropriate waste disposal facility in accordance with current applicable laws and regulations, and product characteristics at time of disposal.

7. HANDLING AND STORAGE

HANDLING

Avoid prolonged repeated skin contact. Avoid contact with eyes. Wear safety glasses. Avoid inhalation of vapours or mists. Use in well ventilated area away from all ignition sources. Take special care to avoid static electric discharge. Keep container closed.

STORAGE

Store in a cool area. Do not pressurise, cut, heat or weld containers- residual vapours are flammable. This product is combustible and will fuel a fire in progress.

8. EXPOSURE CONTROLS AND PERSONAL PROTECTION

EXPOSURE LIMITS

No value assigned for this specific material by New Zealand Occupational Safety and Health Service (OSH).

ENGINEERING MEASURES

Ensure adequate ventilation, especially in confined areas.

PERSONAL PROTECTIVE EQUIPMENT

Impervious gloves, tightly fitting safety goggles, chemical resistant apron and boots. Suitable respiratory equipment will be needed if adequate ventilation cannot be engineered.

HYGIENE MEASURES

Avoid contact with skin, eyes and clothing. Wash hands before breaks and at the end of workday.

PROTECTIVE MEASURES

Avoid exposure - obtain special instructions before use. Wear suitable gloves and eye/face protection.

9 PHYSICAL AND CHEMICAL PROPERTIES

Appearance & Odour:	Low viscosity liquid in various colours with a solvent odour
Density	about 0.800kg/l
Boiling Range	195 – 203C
Flash Point	63C
Vapour Pressure	0.069 mm Hg at 20C
Vapour Density	>1.0 (Air=1)
Solubility in Water	Negligible
% Volatile Matter	65g/Litre
Flammability Limits	0.7 Lower (LEL) 5.4 Upper (UEL)
Auto Ignition Temp:	365C

10. STABILITY AND REACTIVITY

REACTIVITY DATA

Stable at room temperature and pressure. Avoid sources of heat and ignition, open flames.

HAZARDOUS DECOMPOSITION BY PRODUCTS

Carbon dioxide and carbon monoxide.

HAZARDOUS POLYMERISATION

Will Not Occur

11. TOXICOLOGICAL INFORMATION

ACUTE EFFECTS OF OVEREXPOSURE

INGESTION

Small amounts of liquid aspirated into the lungs during ingestion, or from vomiting, may cause chemical pneumonitis, or pulmonary oedema. Ingesting large amounts of this product will result in headaches, nausea, dizziness and tracheal burning.

SKIN CONTACT

This product is irritating to the skin with prolonged exposure. It may result in dryness and cracking of the skin.

INHALATION

Vapour concentrations above recommended exposure levels are irritating to the nose and throat. The inhalation of this product in large quantities will yield moderate discomfort.

Over exposure may be evident through symptoms of dizziness, nausea, headaches and other central nervous system effects.

EYE CONTACT

This product may be strongly irritating to the eyes but will not permanently damage the eye tissue.

MUTAGENIC EFFECTS

None

REPRODUCTIVE EFFECTS

None

CHRONIC EFFECTS

No chronic health data is available for this product.

12. ECOLOGICAL INFORMATION

AVOID CONTAMINATING WATERWAYS.

ENVIRONMENTAL FATE, PERSISTENCE, AND DEGRADATION

This material is biodegradable.

AQUATIC ECOTOXICITY

Toxic for aquatic organisms.

DISPOSAL CONSIDERATIONS

This product can degrade rapidly in air. Expected to be removed in wastewater treatment. Based upon data for similar components or estimated data, this product is expected to be biodegradable according to OECD guidelines.

13 DISPOSAL CONSIDERATIONS

Dispose of in an approved waste facility operated by an authorised contractor in compliance with local regulations. Decontamination and destruction of containers should be considered

14. TRANSPORT INFORMATION

Not classified as a Dangerous Good according to NZS 5433:2007 Transport of Dangerous Goods on Land.

15. REGULATORY INFORMATION

IOKA EXTERIOR OIL has been assigned to Surface Coatings and Colourants (Subsidiary Hazard) Group Standard 2017 HSR002670

The following hazard classifications have been assigned to IOKA EXTERIOR OIL:

- 3.1D Flammable Liquid: Low Hazard 60C< Flash Point <93C
- 6.1E Acutely Toxic.
- 6.3A Irritating to Skin
- 6.5 B Contact Sensitisers
- 9.1 C Harmful to the aquatic environment or are otherwise designed for biocidal action.

16. OTHER INFORMATION

ABBREVIATIONS

ACGIH	The American Conference of Governmental Industrial Hygienists, Inc.
AIHA	American Industrial Hygiene Association
AS/NZS	Australian/New Zealand Standard
C	Celsius, a measure of temperature
CAS	Chemical Abstract Services
EPA	Is New Zealand's Environmental Protection Authority
GHS	Globally Harmonised System
LEL	Lower Explosion Limit
LC50	Is the concentration which kills half of the test animals under controlled conditions. This value applies to vapours, dusts, mists and gases.
LCLo	Is the lowest concentration of a material in air reported to have caused the death of animals or humans. The exposure may be acute or chronic. This is also called the lowest concentration causing death, lowest detected lethal concentration, and lethal concentration low. LCLo is closely related to the LC50 value which is the concentration which kills half of the test animals under controlled conditions. This value applies to vapours, dusts, mists and gases. Solids and liquids use the closely related LDLo value for routes other than inhalation.
LD50	Is the dose which kills half of the test animals by ingestion.
LDLo	Is the lowest dose of a material in reported to have caused the death of animals or humans. The exposure may be acute or chronic. This is also called the lowest dose causing death, lowest detected lethal concentration, and lethal dose low.
PEL	Permissible Exposure Limit is the maximum amount or concentration of a chemical that a worker may be exposed to under OSHA regulations.
SDS	Safety Data Sheet, the new term for MSDS or Material Safety Data Sheet.
STEL	A Short Term Exposure Limit (is defined by ACGIH as the concentration to which workers can be exposed continuously for a short period of time without suffering from: irritation, chronic or irreversible tissue damage narcosis of sufficient degree to increase the likelihood of accidental injury, impair self-rescue or materially reduce work efficiency.
TWA	Time-Weighted Average
UEL	Upper Explosion Limit
UN	United Nations
WEEL	Workplace Environmental Exposure Levels

DRYDEN[®]

THE NATURAL CHOICE FOR YOUR TIMBER

OilStain – Product Data Sheet

1. PRODUCT ATTRIBUTES

This product:

- is a deeply penetrating oil that nourishes timber from within
- has water resistant properties that helps prevent the absorption of water into timbers, reducing excessive warping, cupping, and splitting of timber, thus extending the life span of those timbers.
- It does not film on the surface, and therefore will not crack, flake, or peel. When applied without the addition of a *Dryden Colourtone+*, the timber will weather naturally and silver over time.
- can have *Dryden Colourtone+* added to provide UV protection to the timber, helping to prevent the timber from silvering.
- Has an added fungicide to help resist mould growth.
- can have *Dryden Colourtone+* added to create a wide range of colours from lighter tones through to modern dark tones while retaining the texture and grain of the timber.
- Is suitable for application on decking, hardwood, outdoor furniture and other exterior timbers.

Note: When *Dryden OilStain Clear* is applied, timber in exposed environments will weather naturally and silver over time. This means that the natural timber colour will be maintained under covered areas while transitioning out to silver in exposed areas. *Dryden Colourtone+* 'Slate' can be used, if a natural uniform look is required.

2. PRODUCT SUITABILITY

This product:

- *Dryden OilStain* is suitable for most exterior timber species, such as softwoods like Western Red Cedar, Radiata Pine, Macrocarpa, Larch, Redwood and hardwoods like Purpleheart, Garapa, Vitex, Kwila, Tonka, Rosewood, Iroko and Jarrah, as well as other timber products such as Modified Timbers, Plywood and Laminated Timbers.
- *Dryden OilStain* is suitable for decking & outdoor furniture, new and old timbers, and dressed and bandsawn timbers.

3. COLOURTONE+

Dryden Colourtone+ can be added to the *Dryden* OilStain 'Clear' to provide UV protection to timber, preventing silvering when maintained correctly. It is recommended that when a colour is chosen, that for maximum retention it is used in all applications of *Dryden* OilStain. The final finished colour will also be influenced by the timber type, colour, grain, and product application.

Dryden Colourtones+ printed on paper, internet website, colour chips, and liquid samples are a representative guide only as the timber type, actual raw timber colour, exposure and seasoning of timbers, and the quantity of oil applied, will determine the final colour achieved.

Note: Timber suppliers/manufacturers may have restrictions on colour options across some timber profiles or timber species in their range. *Dryden* recommends you check with your Timber Supplier/Manufacturer on colour limitations for your project.

4. COVERAGE RATES

Coverage Rates (approximate only)

Timber type	Coverage rate (m ² /litre)
Bandsawn Timber (Low Density)	6-10
Dressed Timber (Low Density)	9-12
Hardwood Timber (High Density)	12-14
Bandsawn Plywood	6-8
Restored Timbers (Low Density)	6-8

Dryden OilStain coverage rates are approximate only and may need to be adjusted at times to match the timber. Allow *Dryden* OilStain to penetrate for 30-60 minutes before wiping off any excess with a dry applicator or cloth.

When applying a second coat or a maintenance re-coat, application rates will vary depending on the timber's exposure (covered/uncovered etc) and the time frame between coats or since the timber was last given a maintenance coat.

Note: When there is excessive absorption into restored timbers, *Dryden* recommends a change of application method. This will allow for a lower-than-normal coverage rate to match the timber porosity, being mindful that any excess should be wiped free of the surface 30-60minutes post application.

5. COATING SYSTEMS

Exterior: Two coat system

First Coat factory applied, or site applied prior to fixing.

Second Coat 24 hours after first coat.

6. APPLICATION TOOLS

Dryden OilStain applies easily and rapidly. It can be applied using a:

- **Speedbrush:** Preferred application method. Fine bristled speedbrush (not lambskin or long pile speedbrush).
- **Spray:** Use airless spray equipment.
- **Brush:** For uneven or rough surfaces, a wide good quality bristle brush is best.
- **Roller:** Use a medium nap for most timbers.

7. COATING ENVIRONMENT

All timbers delivered to site must be protected and covered from rain, environmental grime, concrete, cement dust, metal filings, and site contaminants. All coated/uncoated timber must be stored off the ground when not fixed.

Temperature Ranges:

The precoating application done in factory or building site should be completed in a suitable environment, with adequate lighting, ventilation, and air temperatures between 12°C and 25°C, with humidity <75%.

Moisture Content:

Do not apply to exposed timber if rain is expected within 6-8 hours of application. *Dryden OilStain* should only be applied to dry timbers (dry weather is ideal).

Timber moisture content must not exceed 18%.

Substrate Standard:

If any substrate or surface cannot be brought up to the standard that will allow the coating to perform as specified, then do not proceed until remedial work is carried out.

8. SURFACE PREPARATION

Preparing Dressed Timber

For best results, we recommend cleaning timber with *Dryden Liquid Timber Clean* to ensure surface is free from debris, droppings, and stains.

Preparing Bandsawn Timber:

Thoroughly brush along the direction of the grain to remove dust, loose timber fibres and debris. After brushing, turn over the timber and knock several times to ensure all loose fibres fall off. For best results, we recommend cleaning timber with Dryden Liquid Timber Clean to ensure surface is free from debris, droppings and stains

Protect:

Protect newly coated timber from damage. Take all relevant precautions to protect timbers from sub trade and sources of contamination such as dust, dirt, aggregate concrete wash, concrete cutting, metal grinding, paint splatter, etc.

Envelope Seal all Exterior Timbers:

All timbers should be coated with *Dryden OilStain* prior to installation or fixing to provide a first coat envelope seal. All faces, backs, edges and cut ends must be coated.

Restoration & Refurbishment: (refer to section 13)

Where timber is heavily weathered, previously coated, or showing signs of environmental contamination that require restoration and refurbishment, make sure to bring the surface of the timber up to standard before applying *Dryden OilStain*.

9. PRODUCT PREPARATION

For UV protection of the timber, all contents of the *Dryden Colourtone+* container must be added to the *Dryden OilStain 'Clear'* base. Trying to alter the colour of *Dryden OilStain* by adding less *Dryden Colourtone+* will result in less UV protection of the timber.

Dryden OilStain with *Dryden Colourtone+* must be thoroughly stirred until the colour is even and fully mixed prior to use.

For projects that require more than one pail of the same colour, box all pails together to ensure a consistent colour is achieved.

Mixing and Adding:

- Check the *Dryden Colourtone+* colour supplied prior to starting against specification documents and colour samples.
- Always mix outdoors or in a well-ventilated area.
- Shake the *Dryden Colourtone+* container vigorously for approximately 3 minutes before adding it to *Dryden OilStain 'Clear'* base.
- Re-check the *Dryden Colourtone+* colour prior to adding it to *Dryden OilStain 'Clear'* base.
- Add *Dryden Colourtone+* to *Dryden OilStain 'Clear'* base and stir until the colour is even and fully mixed.

Note: In the event a small amount of *Dryden Colourtone+* is still in the container (after adding to *Dryden OilStain*), add a small amount of *Dryden OilStain* to the *Dryden Colourtone+* container and re-shake vigorously then re-add contents to *Dryden OilStain*.

10. PRODUCT APPLICATION

Check all products supplied prior to starting against specification documents and colour samples.

Dryden OilStain must be used as supplied. Never add thinners or alter it in any way.

Dryden OilStain needs to be stirred regularly (with or without *Colourtone+* added) to ensure a consistent product and colour is applied. *Dryden Colourtone+* will settle out from the *Dryden OilStain* if it is not stirred regularly.

For projects that require more than one pail of the same colour, box all pails together to ensure a consistent colour is achieved.

Coat the timbers full length linearly (do not stop mid-section) and complete individual walls at one time, using good coating practices.

When completed, the entire area should be uniform in look and colour (when *Dryden Colourtone+* has been used) and free from coating defects.

FIRST COAT

SCENARIO	RECOMMENDED ACTION
First coat (factory applied)	<i>Dryden OilStain</i> can be applied by Factory Pre-coaters; their systems allow <i>Dryden OilStain</i> to be coated within a controlled environment delivering an envelope seal to timber profiles, prior to delivery to the site. When timber has been factory coated, <u>ensure all cut ends are coated during fixing.</u>
First coat (site applied)	Prior to fixing, a first coat must be applied to all faces and cut ends, to provide an envelope seal. Timber should be free from raised or woolly grain, planing burrs, or other machining defects. On-site coated timber must be racked or laid out on the back face, off ground, in a clean well vented location for 24 hours at 12-25°C, with humidity <75%, free from sub-trade contamination. Any excess or wet look must be gone prior to fillet stacking face-to-face. Stacked timber must be protected and covered from rain, environmental grime, concrete or cement dust, metal filings and site contaminants. All coated timber must be stored off the ground when not fixed. When timber has been coated on site, <u>ensure all cut ends are coated during fixing.</u>
Cut ends	All exterior timber cut ends must be coated, prior to fixing, with the same product and colour that was used to pre-coat the timber. When coating cut ends, care must be taken not to create lap marks on aesthetic faces. <u>Note: Do not use <i>Dryden WaxEndSeal</i> to seal these areas.</u>

Exposed Ends; *Dryden WaxEndSeal*

- For Architectural builds with exposed timber ends, such as beams, posts, and screens, use *Dryden WaxEndSeal*.
- *Dryden WaxEndSeal* is a wax emulsion for sealing exposed ends of timber.
- *Dryden WaxEndSeal* must be applied after appropriate coats of *Dryden OilStain* (with or without *Dryden Colourtone+*) have been left to penetrate for a minimum of 24 hours
- Be sure to avoid *Dryden WaxEndSeal* on any aesthetic faces.

Refer to the *Dryden WaxEndSeal* Data Sheet for further information.

SECOND COAT

New Timber

Second coat – minimum 24 hours after application of the first coat.

11. COMPATIBILITY WITH OTHER PRODUCTS

Chemically Treated Timber:

- LOSP-treated timber (Light Organic Solvent Preservative) must NOT be coated until the chemicals & solvents in the treatment process have evaporated from the timber. Refer to the supplied LOSP timber manufacturer's Data Sheet.
- H1-H6 Hazard treatment coded timbers are *Dryden OilStain* compatible as long as they do not offer water repellence. Please refer to the timber manufacturer's Data Sheet.

Rubber & Butyl Surfaces:

- *Dryden OilStain* can affect rubber adhesives and butyl surfaces if not washed/wiped off soon after contact. *Dryden OilStain* applied to wooden shingles does not usually affect the butyl underlay. It is accepted that most of the industry now uses non-rubber-based glues. Enquiries should be made to the manufacturer. If coating around butyl surfaces, be sure to keep all surrounding surfaces protected and clean during and after the application of *Dryden OilStain*.

Preventing Cross Diffusion:

- When absorbent materials need to be attached to timber coated with *Dryden OilStain*, 'stripe' the mating surfaces or edges with recommended coats of a compatible primer as recommended by the manufacturer to prevent cross diffusion into the porous substrate.
- *Dryden* recommends that regardless of which manufacturer's system is being used, all data sheets are read and followed, for their technical requirements and warranties.

Sealants & Adhesives:

- *Dryden* recommends allowing a minimum migration period of 7 days before applying any adhesives or sealants. This ensures that *Dryden OilStain* has penetrated well into the timber. Ensure the timber is clean and free of dust or dirt and use an appropriate primer as recommended by the manufacturer.
- Refer to sealant & adhesives manufacturer data sheets for technical requirements and warranty information.

Hardware:

- Do not coat hinges or hardware that cannot be removed. Carefully remove hardware, fixtures, and fittings before commencing work. Should the product accidentally come in contact with hardware, clean off immediately.

Timber Compatibility:

- *Dryden OilStain* is not compatible with Bamboo or other grasses (Monocotyledons)

Harvesting Rainwater:

- Rainwater that comes into contact with timber coated with *Dryden OilStain* is not suitable for drinking.

12. CARE AND MAINTENANCE

- Maintenance time varies widely according to many factors including the age and porosity of the timber, species, situation and exposure to weather. *Dryden OilStain* should be re-applied when the timber has lost its water resistance and water is soaking into the timber. We recommend routine maintenance inspections every six months to ensure the timber is still protected from water, or as frequently as necessary to retain your preferred timber appearance.
- *Dryden* recommends a 6 monthly soft water washing of the surface to remove surface contaminants such as dust and pollen.
- Wash with clean water using a garden hose or soft brush (such as a car washing brush). A mild detergent solution can be used to remove stubborn contaminants.
- Conduct a maintenance inspection of the coating at the same time as washing. When *Dryden Colourtones+* are showing signs of chalking and fading this is a signal of maintenance being required and is normal.
- **Note:** *Dryden Colourtones+* that are faded or chalked or when timber starts to show signs of dryness and loss of colour, clean to an even finish using *Dryden Liquid Timber Clean*. Apply 1 coat of *Dryden OilStain* with added *Colourtone+*, wiping off the surface excess.

First maintenance is determined by the quality of application of the first coating, building design, orientation to the sun, weather exposure, chosen colour, timber type, and grain.

13. RESTORATION & REFURBISHMENT

Where timber is heavily weathered, previously coated, or showing signs of environmental contamination that require restoration and refurbishment, make sure to bring the surface of the timber up to standard before applying *Dryden OilStain*

Heavily neglected weathered timber

Heavily neglected timber that has been left to weather and had little maintenance carried out over many years, showing severe stress, (e.g. dryness, cracked and split, badly cupped, protruding nails) will require a strong wash with *Dryden Liquid Timber Clean* prior to coating.

- All restoration work must be carried out prior to coating and may include the replacement of timbers that are not salvageable. Refer to a Registered Builder for advice.
- *Dryden* recommends a strong wash using *Dryden Liquid Timber Clean* as per maintenance not carried out on time.

Pre-stained surfaces

- Degraded stains and polyurethane surfaces must be stripped back to bare timber prior to the application of *Dryden OilStain*.
- *Dryden* recommends a preparation wash with *Dryden Liquid Timber Clean* to remove the degraded loose product.
- After a strong wash, inspect the timber surface for any old coating remaining, spot stripping may be required if not fully removed. All coatings must be removed before coating with *Dryden OilStain*.
 - Note: Never sand or scrape timber to remove old stains. Spot stripping may be required. Sanding and or scraping will result in patchy sanding or scraping marks on the timber surface that will show through *Dryden OilStain*.

Environmental contamination

- Where timber is weathered, or showing signs of environmental grime, mould, watermarks or discolouration, clean with *Dryden Liquid Timber Clean* prior to applying *Dryden OilStain*.

14. COMPLETION AND CLEAN UP

Clean Up:

- Clean up with mineral turpentine or hot water and detergent for spray equipment, brushes, and clothes.
- These also help with over-spray or accidental spillage on unwanted surfaces such as windows; use a wiping rag on smooth surfaces and a brush on rough surfaces.

Remove:

- Remove drop sheets, coverings, and masking to leave surrounding surfaces and areas clean, tidy, and undamaged.
- Dispose of all materials safely.
- Do not pour unused *Dryden OilStain* down the drain. Unwanted *Dryden OilStain* should be brushed out on newspaper or absorbed with sawdust, then disposed of via waste collection.
- Disposal of empty paint containers via domestic recycling programs may differ between local authorities. For more information on responsible disposal of paint and packaging visit painttakeback.co.nz.

Protect:

- Protect new work from damage. Take all relevant precautions to protect timbers from site work, dust, dirt, aggregate concrete wash, concrete cutting, metal grinding, water blasting, paint splatter, etc.

15. TECHNICAL

Dryden OilStain Light Reflective Values (LRV)

Standard Light Reflectance Values cannot be determined for semi-transparent coatings. A transparent coating allows light to pass through and interact with the underlying timber which is why as an observer we can see it. It follows that the colour of the timber being coated as well as the number of coats applied will therefore significantly impact the measured LRV.

Dryden do not offer any LRV data for their products.

16. ENVIRONMENTAL HAZARDS

Hazards	Guidelines
Accidental release measures	Clear area of all unprotected personnel. Slippery when spilt. Wear protective equipment. Absorb with sand or soil. Collect and seal in properly labelled drums.

17. STORAGE

Before storing, box all like-for-like containers.

Do not store directly on concrete or cold surfaces, or in damp poorly ventilated environments.

The product is best stored off ground in a well-ventilated area at a consistent moderate temperature.

Plastic containers containing *Dryden OilStain* can flex, particularly if stored in conditions that vary constantly in temperature.

Do not use or store near heat or open flame.

18. PERSONAL PROTECTION EQUIPMENT (PPE) PRECAUTIONS

Always wear appropriate PPE such as protective gloves, eye protection and face protection.

When spraying or in case of inadequate ventilation, wear respiratory protection.

Wash skin thoroughly after handling with hot soapy water.

Refer to the *Dryden OilStain* Safety Data Sheet for detailed information.

19. FIRST AID

If poisoning occurs, contact a doctor or the Poisons Information Centre (New Zealand 0800 764 766; Phone Australia 131 126). If medical advice is needed, have a product container or label at hand.

- **Swallowed:** If swallowed, do NOT induce vomiting. Give a glass of water. Seek medical assistance.
- **Eye:** If in eyes, hold eyes open, flood with water for at least 15 minutes and see a doctor.
- **Skin:** If skin contact occurs, remove contaminated clothing and wash skin thoroughly. If irritation occurs seek medical advice.
- **Inhaled:** Remove from contaminated area. Apply artificial respiration if not breathing. Seek medical advice.

For special medical advice and emergencies

Call NZ 0800 734 607, AUST 1800 033 111

20. FURTHER INFORMATION

The responsibility for products sold is subject to our standard terms and conditions.

For further information:



Contact **0800 379 336** or



Click on www.dryden.co.nz

The sale of this product is subject to our standard conditions of sale.

Dryden is a registered trade mark of DuluxGroup (New Zealand) Pty Ltd

Safety Data Sheet

DRYDEN

Hazardous, NON-Dangerous Goods

1. MATERIAL AND SUPPLY COMPANY IDENTIFICATION

Product name: DRYDEN OIL STAIN DECKING HARDWOOD & OUTDOOR FURNITURE

Synonyms	Product Code	Bar Code
Dryden OilStain Decking, Hardwood & Outdoor Furniture Clear 1L	DOSW0526-1L	9400513213507
Dryden OilStain Decking, Hardwood & Outdoor Furniture Clear 4L	DOSW0526-4L	9400513213514
Dryden OilStain Decking, Hardwood & Outdoor Furniture Clear 10L	DOSW0526-10L	9400513213521

Recommended use: Coating for timber

Supplier: Dulux New Zealand, a division of DuluxGroup (New Zealand) Pty Ltd
Company No.: 55 133 404 118 / Co. 2355191
Street Address: 150 Hutt Park Road
Lower Hutt
New Zealand
Telephone: 0800 800 424

Emergency Telephone number: Australia – 1800 220 770; New Zealand – 0800 220 770

2. HAZARDS IDENTIFICATION

This material is hazardous according to the criteria of EPA New Zealand GHS 7.

EPA Group Standard: HSR002657 - Surface Coatings and Colourants (Combustible) Group Standard 2020



Signal Word
Danger

Hazard Classifications

Flammable Liquids - Category 4
Aspiration Hazard - Category 1
Serious Eye Damage/Irritation - Category 2
Sensitisation - Skin - Category 1

Hazard Statements

H227 Combustible liquid.
H304 May be fatal if swallowed and enters airways.
H317 May cause an allergic skin reaction.
H319 Causes serious eye irritation.

Prevention Precautionary Statements

P102 Keep out of reach of children.
P103 Read carefully and follow all instructions.
P210 Keep away from heat/sparks/open flames/hot surfaces. No smoking.

Product Name: DRYDEN OIL STAIN DECKING HARDWOOD & OUTDOOR FURNITURE

Reference No: DLXNZ7EN004423

Issued: 14 August 2023

Version: 2.0

Page 1 of 7

Safety Data Sheet

DRYDEN

P261 Avoid breathing dust, fume, gas, mist, vapours or spray.
P264 Wash hands, face and all exposed skin thoroughly after handling.
P272 Contaminated work clothing should not be allowed out of the workplace.
P280 Wear protective gloves/protective clothing including eye/face protection.

Response Precautionary Statements

P101 If medical advice is needed, have product container or label at hand.
P301+P310 IF SWALLOWED: Immediately call a POISON CENTER/doctor.
P302+P352 IF ON SKIN: Wash with plenty of water and soap.
P305+P351+P338 IF IN EYES: Rinse cautiously with water for several minutes. Remove contact lenses, if present and easy to do. Continue rinsing.
P331 Do NOT induce vomiting.
P333+P313 If skin irritation or rash occurs: Get medical advice/attention.
P337+P313 If eye irritation persists: Get medical advice/attention.
P363 Wash contaminated clothing before reuse.

Storage Precautionary Statements

P403+P235 Store in a well-ventilated place. Keep cool.
P405 Store locked up.

Disposal Precautionary Statement

P501 Dispose of contents/container in accordance with local, regional, national and international regulations.

DANGEROUS GOOD CLASSIFICATION

Not classified as Dangerous Goods by the criteria of the "Australian Code for the Transport of Dangerous Goods by Road & Rail" and the "New Zealand NZS5433: Transport of Dangerous Goods on Land".

3. COMPOSITION INFORMATION

CHEMICAL ENTITY	CAS NO	PROPORTION
Distillates, petroleum, hydrotreated light	64742-47-8	30 - 60 % (w/w)
Iodopropynyl Butylcarbamate	55406-53-6	<1 % (w/w)
Ingredients determined to be non-hazardous or below reporting limits		Balance
		100%

4. FIRST AID MEASURES

If poisoning occurs, contact a doctor or Poisons Information Centre (Phone Australia 131 126, New Zealand 0800 764 766).

Inhalation: Remove victim from exposure - avoid becoming a casualty. Remove contaminated clothing and loosen remaining clothing. Allow patient to assume most comfortable position and keep warm. Keep at rest until fully recovered. Seek medical advice if effects persist.

Skin Contact: Effects may be delayed. If skin or hair contact occurs, remove contaminated clothing and flush skin and hair with running water. If swelling, redness, blistering or irritation occurs seek medical assistance. For gross contamination, immediately drench with water and remove clothing. Continue to flush skin and hair with plenty of water (and soap if material is insoluble). For skin burns, cover with a clean, dry dressing until medical help is available. If blistering occurs, do NOT break blisters. If swelling, redness, blistering, or irritation occurs seek medical assistance.

Eye contact: If in eyes, hold eyelids apart and flush the eyes continuously with running water. Continue flushing

Product Name: DRYDEN OIL STAIN DECKING HARDWOOD & OUTDOOR FURNITURE

Reference No: DLXNZ7EN004423

Issued: 14 August 2023

Version: 2.0

Page 2 of 7

Safety Data Sheet

DRYDEN

until advised to stop by the Poisons Information Centre or a Doctor; or for at least 15 minutes and transport to Doctor or Hospital.

Ingestion: Immediately rinse mouth with water. If swallowed, do NOT induce vomiting. Give a glass of water to drink. Never give anything by the mouth to an unconscious patient. If vomiting occurs give further water. Immediately call Poisons Centre or Doctor.

PPE for First Aiders: Wear safety shoes, overalls, gloves, chemical goggles, respirator. Use with adequate ventilation. If inhalation risk exists wear organic vapour/particulate respirator meeting the requirements of AS/NZS 1715 and AS/NZS 1716. Available information suggests that gloves made from nitrile rubber should be suitable for intermittent contact. However, due to variations in glove construction and local conditions, the user should make a final assessment. Always wash hands before smoking, eating, drinking or using the toilet. Wash contaminated clothing and other protective equipment before storing or re-using.

Notes to physician: Treat symptomatically. Effects may be delayed.

5. FIRE FIGHTING MEASURES

Hazchem Code: Not applicable.

Suitable extinguishing media: If material is involved in a fire use water fog (or if unavailable fine water spray), alcohol resistant foam, standard foam, dry agent (carbon dioxide, dry chemical powder).

Specific hazards: Combustible liquid.

Fire fighting further advice: On burning or decomposing may emit toxic fumes. Fire fighters to wear self-contained breathing apparatus and suitable protective clothing if risk of exposure to vapour or products of combustion or decomposition.

6. ACCIDENTAL RELEASE MEASURES

SMALL SPILLS

Wear protective equipment to prevent skin and eye contamination. Avoid inhalation of vapours or dust. Wipe up with absorbent (clean rag or paper towels). Collect and seal in properly labelled containers or drums for disposal.

LARGE SPILLS

If safe to do so, shut off all possible sources of ignition. Clear area of all unprotected personnel. Slippery when spilled. Avoid accidents, clean up immediately. Wear protective equipment to prevent skin and eye contamination and the inhalation of vapours. Work up wind or increase ventilation. Contain - prevent run off into drains and waterways. Use absorbent (soil, sand or other inert material). Use a spark-free shovel. Collect and seal in properly labelled containers or drums for disposal. If contamination of crops, sewers or waterways has occurred advise local emergency services.

Dangerous Goods - Initial Emergency Response Guide No: Not applicable

7. HANDLING AND STORAGE

Handling: Avoid eye contact and skin contact. Avoid inhalation of vapour, mist or aerosols.

Storage: Store in a cool, dry, well-ventilated place and out of direct sunlight. Store away from foodstuffs. Store away from incompatible materials described in Section 10. Store away from sources of heat and/or ignition. Store locked up. Keep container standing upright. Keep containers closed when not in use - check regularly for leaks.

8. EXPOSURE CONTROLS / PERSONAL PROTECTION

Product Name: DRYDEN OIL STAIN DECKING HARDWOOD & OUTDOOR FURNITURE

Reference No: DLXNZ7EN004423

Issued: 14 August 2023

Version: 2.0

Page 3 of 7

Safety Data Sheet

DRYDEN

National occupational exposure limits: No value assigned for this specific material by WorkSafe New Zealand.

Biological Limit Values: As per the WorkSafe New Zealand the ingredients in this material do not have a Biological Limit Allocated.

Engineering Measures: Natural ventilation should be adequate under normal use conditions.

Personal Protection Equipment: SAFETY SHOES, OVERALLS, GLOVES, CHEMICAL GOGGLES, RESPIRATOR.

Wear safety shoes, overalls, gloves, chemical goggles, respirator. Use with adequate ventilation. If inhalation risk exists wear organic vapour/particulate respirator meeting the requirements of AS/NZS 1715 and AS/NZS 1716. Available information suggests that gloves made from nitrile rubber should be suitable for intermittent contact. However, due to variations in glove construction and local conditions, the user should make a final assessment. Always wash hands before smoking, eating, drinking or using the toilet. Wash contaminated clothing and other protective equipment before storing or re-using.

Hygiene measures: Keep away from food, drink and animal feeding stuffs. When using do not eat, drink or smoke. Wash hands prior to eating, drinking or smoking. Avoid contact with clothing. Avoid eye contact and skin contact. Avoid inhalation of vapour, mist or aerosols. Ensure that eyewash stations and safety showers are close to the workstation location.

9. PHYSICAL AND CHEMICAL PROPERTIES

Form: Liquid
Colour: Clear
Odour: Mild solvent

Solubility: Insoluble in water
Specific Gravity: 0.8 - 0.9
Relative Vapour Density (air=1): >1
Vapour Pressure: N Av
Flash Point (°C): >62
Flammability Limits (%): N Av
Autoignition Temperature (°C): N Av
Melting Point/Range (°C): N Av
Boiling Point/Range (°C): N Av
pH: N App
Viscosity: <14 mm²/sec @ 40 °C
Total VOC (g/Litre): N Av

(Typical values only - consult specification sheet)

N Av = Not available, N App = Not applicable

10. STABILITY AND REACTIVITY

Chemical stability: This material is thermally stable when stored and used as directed.

Conditions to avoid: Elevated temperatures and sources of ignition.

Incompatible materials: Oxidising agents.

Hazardous decomposition products: Oxides of carbon and nitrogen, smoke and other toxic fumes.

Hazardous reactions: No known hazardous reactions.

11. TOXICOLOGICAL INFORMATION

No adverse health effects expected if the product is handled in accordance with this Safety Data Sheet and the product label. Symptoms or effects that may arise if the product is mishandled and overexposure occurs are:

Acute Effects

Inhalation: Material may be an irritant to mucous membranes and respiratory tract.

Skin contact: Contact with skin may result in irritation. A skin sensitiser. Repeated or prolonged skin contact may lead to allergic contact dermatitis.

Ingestion: Swallowing can result in nausea, vomiting and irritation of the gastrointestinal tract. May cause lung damage if swallowed. Small amounts of liquid aspirated into the respiratory system during ingestion or vomiting may cause bronchopneumonia or pulmonary oedema.

Eye contact: An eye irritant.

Acute toxicity

Inhalation: This material has been classified as not hazardous for acute inhalation exposure. Acute toxicity estimate (based on ingredients): $LC_{50} > 20.0$ mg/L for vapours or $LC_{50} > 5.0$ mg/L for dust and mist.

Skin contact: This material has been classified as not hazardous for acute dermal exposure. Acute toxicity estimate (based on ingredients): $LD_{50} > 2,000$ mg/Kg bw

Ingestion: This material has been classified as not hazardous for acute ingestion exposure. Acute toxicity estimate (based on ingredients): $LD_{50} > 2,000$ mg/Kg bw

Corrosion/Irritancy: Eye: this material has been classified as a Category 2 Hazard (reversible effects to eyes). Skin: this material has been classified as not corrosive or irritating to skin.

Sensitisation: Inhalation: this material has been classified as not a respiratory sensitiser. Skin: this material has been classified as a Category 1 Hazard (skin sensitiser).

Aspiration hazard: This material has been classified as Aspiration Hazard - Category 1

Specific target organ toxicity (single exposure): This material has been classified as not a specific hazard to target organs by a single exposure.

Chronic Toxicity

Mutagenicity: This material has been classified as non-hazardous.

Carcinogenicity: This material has been classified as non-hazardous.

Reproductive toxicity (including via lactation): This material has been classified as non-hazardous.

Specific target organ toxicity (repeat exposure): This material has been classified as non-hazardous.

12. ECOLOGICAL INFORMATION

Avoid contaminating waterways.

Acute aquatic hazard: This material has been classified as not hazardous for acute aquatic exposure. Acute toxicity estimate (based on ingredients): > 100 mg/L

Chronic aquatic hazard: This material has been classified as not hazardous for chronic aquatic exposure. Non-rapidly or rapidly degradable substance for which there are adequate chronic toxicity data available OR in the

Safety Data Sheet

DRYDEN

absence of chronic toxicity data, Acute toxicity estimate (based on ingredients): >100 mg/L, where the substance is not rapidly degradable and/or BCF < 500 and/or log Kow < 4.

Ecotoxicity in the soil environment: This material has been classified as non-hazardous.

Ecotoxicity to terrestrial vertebrates: This material has been classified as non-hazardous.

Ecotoxicity to terrestrial invertebrates: This material has been classified as non-hazardous.

Ecotoxicity: No information available.

Persistence and degradability: No information available.

Bioaccumulative potential: No information available.

Mobility: No information available.

13. DISPOSAL CONSIDERATIONS

Persons conducting disposal, recycling or reclamation activities should ensure that appropriate personal protection equipment is used, see "Section 8. Exposure Controls and Personal Protection" of this SDS.

If possible material and its container should be recycled. If material or container cannot be recycled, dispose in accordance with local, regional, national and international Regulations.

14. TRANSPORT INFORMATION

ROAD AND RAIL TRANSPORT

Not classified as Dangerous Goods by the criteria of the "Australian Code for the Transport of Dangerous Goods by Road & Rail" and the "New Zealand NZS5433: Transport of Dangerous Goods on Land".

MARINE TRANSPORT

Not classified as Dangerous Goods by the criteria of the International Maritime Dangerous Goods Code (IMDG Code) for transport by sea.

AIR TRANSPORT

Not classified as Dangerous Goods by the criteria of the International Air Transport Association (IATA) Dangerous Goods Regulations for transport by air.

15. REGULATORY INFORMATION

This material is not subject to the following international agreements:

Montreal Protocol (Ozone depleting substances)
The Stockholm Convention (Persistent Organic Pollutants)
The Rotterdam Convention (Prior Informed Consent)
Basel Convention (Hazardous Waste)
International Convention for the Prevention of Pollution from Ships (MARPOL)

This material/constituent(s) is covered by the following requirements:

NZ EPA Status: All components of this product are listed on or exempt from the New Zealand Inventory of Chemical (NZIoC).

AIICS Status: All components of this product are listed on or exempt from the Australian Inventory of Industrial Chemicals (AIIC).

EPA Group Standard: HSR002657 - Surface Coatings and Colourants (Combustible) Group Standard 2020

Product Name: DRYDEN OIL STAIN DECKING HARDWOOD &
OUTDOOR FURNITURE

Reference No: DLXNZ7EN004423

Issued: 14 August 2023

Version: 2.0

Page 6 of 7

16. OTHER INFORMATION

Reason for issue: Revised

This Safety Data Sheet has been prepared by Chemical Data Services Pty Ltd (chemdata.com.au) on behalf of its client.

Safety Data Sheets are updated frequently. Please ensure that you have a current copy.

This SDS summarises at the date of issue our best knowledge of the health and safety hazard information of the product, and in particular how to safely handle and use the product in the workplace. Since the company cannot anticipate or control the conditions under which the product may be used, each user must, prior to usage, review this SDS in the context of how the user intends to handle and use the product in the workplace.

If clarification or further information is needed to ensure that an appropriate assessment can be made, the user should contact this company.

Our responsibility for product as sold is subject to our standard terms and conditions, a copy of which is sent to our customers and is also available upon request.

28th August 2019

Re: Durability and suitability of imported Japanese cedar for weatherboards

Dear Graham,

Your imported timber samples were analysed by our Wood Anatomy specialist confirming it to be **Japanese cedar (*Cryptomeria japonica*)**. Letter is attached.

Japanese cedar heartwood is rated as durable in the northern hemisphere (Bootle 1983). Stake tests are a standard method for determining a natural durability classification. Testing conducted at Scion on imported Japanese cedar heartwood at Whakarewarewa test site had an average life exceeding eight years giving them a durability classification of 2. Imported western red cedar (*Thuja plicata*) stakes tested on the same site had a similar durability classification. Locally grown Japanese cedar heartwood stakes had a significantly lower durability classification of 3, similar to that of locally grown western red cedar, redwood (*Sequoia sempervirens*), and macrocarpa (*Cupressus macrocarpa*) heartwood. We have not tested Japanese cedar as weatherboards but tests of uncoated macrocarpa, local western red cedar and local redwood weatherboards have all been in place here at Scion since 1987 and show no significant decay.

Stake tests of H3.1 LOSP treated pine, currently also accepted as suitable for use as weatherboards in New Zealand, had an average life similar to that of the locally grown species stakes.

Based on these results and on the overseas durability classification, imported Japanese cedar heartwood weatherboards should easily meet the minimum durability requirement of 15 years.

Yours sincerely,

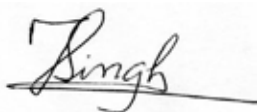

Dr. Tripti Singh
Scientist/Project Leader (Bioactives & Wood Protection)
Scion 49, Sala Street, Private Bag 3020, Rotorua 3046, New Zealand
DDI +64 7 343 5329

RISK AND LIMITATION OF LIABILITY: Scion's liability to the Client arising out of all claims for any loss or damage resulting from this work will not exceed in aggregate an amount equal to two times the Service Fees actually paid by the Client to Scion. Scion will not be liable in any event for loss of profits or any indirect, consequential or special loss or damage suffered or incurred by the Client as a result of any act or omission of Scion under this Agreement.



BEAL Appraisal Certificate



APPRAISAL #: C2549

EXPIRY DATE: 30 November 2026

The SUGI NZ Ltd. Japanese Cedar Weatherboard Cladding System



Product

1.1 The SUGI NZ Ltd.'s Japanese Cedar Weatherboard Cladding System, comprises two Weatherboard Cladding profiles manufactured from Japanese Cedar:

- ⇒ A Shiplap option - either vertical or horizontal - including the STX interlocking Vertical Shiplap profile;
- ⇒ A Bevelback option;

1.2 The SUGI Weatherboard Cladding System is intended to be installed over either timber framing complying with NZS3604, or Light Gauge Steel framing complying with NASH Standard 1.

1.3 The SUGI Weatherboard Cladding System is to be installed under the supervision of an experienced and competent Licensed Building Practitioner in accordance with the manufacturer's instructions.

NZ Building Regulations

2.1 In the opinion of BEAL, the SUGI NZ Ltd.'s Japanese Cedar Weatherboard Cladding System, when designed, installed and maintained in accordance with the statements and conditions of this Appraisal Certificate, will meet the following provisions of the New Zealand Building Code:

Clause B1 STRUCTURE

B1.3.3 (h) – Resistance to wind - there is in-service history to verify the ability of the installed product to resist the forces associated with wind (positive & negative), on buildings up to 10 m in height, demonstrating compliance with clause B1.3.3(h) (Refer para 6.3)

Clause B2 DURABILITY

Performance B2.3.1 (b) 15 years for new or repair work. The SUGI Weatherboard Cladding System will meet this requirement. (Refer para 6.4)

The specified OIKA treatment will comply with performance clause B2.3.1(c) provided the manufacturer's instructions are followed.

Clause E2 EXTERNAL MOISTURE

The SUGI Cedar Weatherboard Cladding System, designed to act as rainscreens, are in accordance with Acceptable Solution E2/AS1, and together with local in-service history of like products, show that when correctly installed, the product will resist the ingress of moisture.

Clause F2 Hazardous Materials

The absence of chemical materials used in the natural product, can be taken as evidence of compliance.

2.2 The SUGI Japanese Cedar Weatherboard Cladding System has been appraised as an 'Alternative Solution' in terms of compliance with the New Zealand Building Code.

Applicant: **SUGI NZ Ltd.**
Unit 10, 69 Marsden Bay Drive,
Marsden, 0118.
P: 027 6600095
E: sales@nznaturaltimber.co.nz
www.sugi.nz

Appraised by: **BEAL**
6B Cedric Place
Plimmerton, Porirua, NZ
P: +64 4 233 6661
E: bts@beal.co.nz
www.beal.co.nz



Scope and Limitations

3.1 SUGI NZ Ltd.'s Japanese Cedar Weatherboard Cladding System is subject to the following scope of use or limitations:

- ⇒ Used in an external environment above ground, with a (seismic) locality factor (Z) of up to 0.42 (Upper Hutt), in a temperate climate, with wind zones up to and including 55m/sec (Extra High);
- ⇒ The design height of residential buildings shall be up to and including 10m from the finished ground level with timber framing constructed as per NZS 3604;
- ⇒ The system is for use over timber framing incorporating a 'frame protection system' and non-structural cavity battens;
- ⇒ The system is limited to use for residential housing including Class 1 and Class 2 type construction, i.e. stand-alone houses and multi-apartment dwellings, up to three stories high;
- ⇒ The system shall be installed in accordance with the approved technical and quality plan literature provided by SUGI NZ Ltd., available from their web site www.sugi.nz
- ⇒ The system shall be installed over a compliant 'frame protection system' (see separate explanatory document available from the BEAL website).

3.2 The owner of the building is responsible for the proper maintenance of the installed SUGI Weatherboard Cladding Claddings as set out in the SUGI technical literature and maintenance advice document that is provided by SUGI NZ Ltd. to the owner along with the product Warranty.

Technical Literature

4.1 The SUGI NZ Ltd. Japanese Cedar Weatherboard Cladding System Installation Manual **Ver 1.1** must be read in conjunction with this Appraisal. All aspects of design, use, installation and maintenance contained within the Technical Literature and scope of this Appraisal Certificate must be followed.

4.2 OIKA cleaner instructions

4.5 OIKA Exterior Oils Specification & Maintenance Guide

4.6 OIKA Exterior Oils MSD sheet

4.7 For a copy of this technical literature please contact SUGI NZ Ltd.

Technical Details

5.1 The SUGI NZ Ltd. products are derived from durable timbers which can be installed over a properly designed timber or light gauge steel frame compliant with the New Zealand Building Code, protected by either a flexible frame protection system or a weatherproof Rigid Air Barrier.

5.2 Components of the SUGI Weatherboard Cladding System include:

- SUGI Interlocking Vertical Shiplap with 110mm cover (135 in width), 20 mm thickness
- SUGI 135/180mm x 21mm Facia

5.3 Accessories supplied by SUGI NZ Ltd. include:

- Fixings – 75 to 90 x 3.15mm Stainless steel or

silicon bronze rose-head annular groove nails, or equivalent screw fixings;

- Battens – 20 x 45mm H3.2 cavity batten (vertically fixed) or 20 x 45mm H3.2 castellated, cavity batten (horizontally fixed);
- µPVC cavity closer to suit;
- Powder-coated aluminium flashings for above windows, internal and external corners, meter boxes, eaves and apron flashings.

Note 1: Fixing centres are 400mm minimum and 600mm maximum.

Note 2: The Weatherboard Claddings are finished using OIKA finishing oil coating system for plywood substrates;

5.4 All components must be stored inside, in a well ventilated area, up off concrete floors, kept dry, out of direct sunlight and away from freezing conditions.

Advice for designers

General

6.1 The SUGI Weatherboard Cladding System is used as a durable, decorative vertical Weatherboard Cladding, used for residential construction.

6.2 Before any installation can be carried out, it is essential that a careful inspection of the framing and frame protection or RAB, is installed as per the manufacture's instructions and as set out in the SUGI Weatherboard Cladding System's technical literature.

Structure - Clause B1.3.3(h)

6.3 The installed SUGI Weatherboard Cladding System has good in-service history in a variety of weather conditions and therefore meets the requirements of the NZBC.

Durability - Clause B2.3.1(b) - 15 years

6.4 The SUGI Weatherboard Cladding System when used in accordance with this Appraisal Certificate, and subject to normal conditions of environment, use, and good maintenance, will have a serviceable life of at least 15 years. Note the requirement under 7.1.

External Moisture - Clause E2.3.2

6.5 The SUGI Weatherboard Cladding System will comply with the requirements of this clause when the system is installed as per the SUGI Weatherboard Cladding System Installation Manual.

Hazardous Building Materials - Clause F2.3.1

6.6 The SUGI Weatherboard Cladding System contains no hazardous materials and will not present a health hazard to people using the building.

Installation Requirements

Installation Skill Requirement

7.1 The SUGI NZ Ltd. SUGI Weatherboard Cladding System must be installed under the supervision of a person who has been trained and approved by SUGI NZ Ltd. NZ Ltd.

Health and Safety

7.4 The safe use and handling of the Weatherboard Claddings and protective coatings are described in the technical literature. The products must be used in conjunction with the relevant materials safety data sheet for each component.

Basis of this Appraisal

BEAL use the compliance verification procedure to demonstrate compliance with the relevant clauses of the NZBC based on a risk analysis procedure. The following is a summary of the technical investigations carried out:

Assessments

8.1 The following assessment of the SUGI Weatherboard Cladding System has been undertaken by BEAL: A review of test data and technical literature supplied by SUGI NZ Ltd. NZ Ltd. Weathertightness was assessed on the basis that the Weatherboard Cladding profiles are in accordance with NZS3617 cited in the Acceptable Solution E2/AS1.

Testing

8.2 The following testing of the SUGI Japanese Cedar (*cryptomeria Japonica*) Weatherboard Cladding System has been undertaken by BEAL:

- MOE and MOR flexural properties for assessment by an engineer
- Fixing shear strength for assessment by an engineer

In-service History

8.3 Heartwood Japanese Cedar (*cryptomeria Japonica*) has been in use overseas for many years and more recently in New Zealand, owing to its resistance to fungal decay resulting from the thermal modification treatment.

Other Investigations

8.4 BEAL investigated the use of heartwood Japanese Cedar both overseas and in New Zealand, finding that other importers were supplying this material for the same purpose as SUGI NZ Ltd.

8.5 The installation of the SUGI Japanese Cedar Weatherboard Cladding System was also evaluated (including site visits) in practical building situations assessing the following;

- Ease of installation
- Potential risks of non-performance when being installed
- Any external factors that could affect the quality of the installed product

Ease of repair or maintenance

8.6 The Technical Literature has been examined by BEAL and found to be satisfactory.

Quality

8.7 The quality of materials, components and

accessories supplied by SUGI NZ Ltd. is managed through the use of a Building Product Quality Plan.

8.9 The SUGI NZ Ltd.'s Building Product Quality Plan, ensures continuous conformance with the quality requirements from purchase to application by experienced and approved tradespersons.

8.10 SUGI NZ Ltd.'s Building Product Quality Plan is reviewed and audited at least annually by BEAL or appointed agent.

8.11 Designers are responsible for the substructure design, and building contractors are responsible for the quality of construction of the substructure or new substrate in accordance with the instructions of the substrate manufacturer and this Appraisal Certificate.

8.12 Building owners are responsible for the maintenance of the SUGI Weatherboard Cladding System in accordance with the manufacturer's instructions and this Appraisal Certificate.

Sources of Information

- The Building Regulations 1992, version Nov 2021
- NZS 3604:2011 Timber framed Buildings
- E2/AS1 Acceptable Solution for demonstrating compliance with performance clause E2.3.2.
- SUGI NZ Ltd. Installation Manual ver 1.0
- The SUGI NZ Ltd. Japanese Cedar Weatherboard Cladding System Building Product Quality Plan (BPQP) Ver 1.1
- NASH Standard Part 1:2016 Design Criteria - Alternative Solution (for Light Gauge Steel framing);
- A letter from SCION dated 28th August 2019 regarding Japanese cedar (*Cryptomeria japonica*) and confirming its durability in New Zealand of at least 15 years.
- BEAL Test Report TR220531-1 MOE/MOR testing
- BEAL Test Report TR220621-2 Fixing pull-through
- BEAL Opinion of weathertightness and Water Management.

Concluding statement

9.1 In the opinion of BEAL, the SUGI Weatherboard Cladding System is fit for purpose and will comply with the NZBC to the extent specified provided that it is used, designed, installed and maintained in accordance with the manufacturer's instructions and this Appraisal Certificate.

The Appraisal Certificate is issued only to SUGI NZ Ltd. NZ Ltd., and is valid until further notification, subject to the conditions of this Appraisal.

Conditions of Appraisal

10.1. This appraisal Certificate:

- a) Relates only to the SUGI Weatherboard Cladding System as described herein;
- b) Must be read, considered and used in full, together with the current version of the Technical Literature
- c) Does not address any legislation, regulations, codes or standards, not specifically named herein;
- d) Is copyright of BEAL

10.2 The Appraisal Certificate holder continues to meet the quality requirements of the SUGI NZ Ltd. NZ Ltd.'s Building Product Quality Plan and has the plan audited and Appraisal certificate revalidated by BEAL on an annual basis.

10.3 SUGI NZ Ltd. NZ Ltd. shall notify BEAL and obtain approval of any changes of the product specification or quality assurance prior to product being marketed including any trade literature, web site info or the like.

10.4 BEAL makes no representation as to:

- a) The nature of individual examples of, batches of, or individual installations of the product, including methods and workmanship;
- b) The presence or absence of any patent or similar rights subsisting in the product or any other product;
- c) Any guarantee or warranty offered by the Appraisal Certificate holder.

10.5 BEAL's verification of the building product or system complying with one or more of the above-mentioned criteria is given on the basis that the criteria used were those that were appropriate to demonstrate compliance with the NZBC at the date of this Appraisal Certificate. In the event that the criteria is withdrawn or amended at a later date, this Appraisal may no longer remain valid.

10.6 Any reference in this Appraisal Certificate to any other publication shall be read as a reference to the version of publication specified in this Appraisal Certificate.

Authorised Signatory,



C R Prouse - Director
BEAL (Building Element Assessment Laboratory Limited)
Updated November 2025.



SUGI

hello@sugi.nz
sugi.nz

SALES

68 Marsden Bay Drive
Marsden
Whangarei 0118
New Zealand
+64 27 660 0095

MILL

28 Gargan Road
Tauriko
Tauranga 3171
New Zealand
+64 27 271 2011